

Multi Party Domain Cryptosystem - Interior – MPDC-I

Revision 1b, October 26, 2024

John G. Underhill – john.underhill@protonmail.com

This document is an engineering level description of the MDPC authenticated network domain crypto-system. This document describes the interior network protocol MPDC-I, a multi-party cryptographic key exchange and network security system.

Contents	Page
Foreword	2
1: Introduction	2
2: Scope	4
3: References	5
4: Terms and Definitions	7
5: Protocol Description	10
6: Mathematical Description	25
7: Security Analysis	50
8: Application Scenarios	56
9: Internal Functions	59

Foreword

This document is intended as the preliminary draft of a new standards proposal, and as a basis from which that standard can be implemented. We intend that this serves as an explanation of this new technology, and as a complete description of the protocol.

This document is the first revision of the specification of MPDC-I, further revisions may become necessary during the pursuit of a standard model, and revision numbers shall be incremented with changes to the specification. The reader is asked to consider only the most recent revision of this draft, as the authoritative expression of the MPDC-I specification.

The inventor and author of this specification is John G. Underhill, and can be reached at john.underhill@protonmail.com

MPDC-I, the algorithm constituting the MPDC-I domain crypto-system is patent pending, and is owned by John G. Underhill and the QRCS Corporation.

1. Introduction

MPDC-I is a multi-party key exchange and network security system. It distributes the security of a key exchange between a server and a client across multiple devices. Network ‘agents’ contribute a portion of pseudo-random material to client-server session keys.

On an interior network, servers and clients exchange a shared secret with each agent on the network using an authenticated asymmetric key exchange. The secret is kept for the lifetime of the devices certificate, and used to generate a unique key-stream to encrypt a small amount of pseudo-random data. This data is called a ‘key fragment’. Fragments are combined and hashed to form the primary session keys used between the server and the client to initialize an encrypted tunnel. In this way, agents on the network that have been authenticated to both the server and client, can inject entropy into a key exchange through multiple independent cryptographic processes.

There can be any number of agents on a network, and each one has a certificate signed by the root domain server. Any attack that utilizes impersonation or ‘man-in-the-middle’ strategies, would need to simultaneously impersonate multiple network devices. The number of agent servers that contribute entropy to a client-server key exchange is unlimited, the generation of a key fragment and fragment encryption use computationally ‘cheap’ symmetric cryptography, and can scale so that even the most sophisticated impersonation attacks are practically impossible. Unlike other multi-party key exchange schemes being considered, which use expensive classical asymmetric cryptographic schemes, MPDC-I explores an asymmetric/symmetric post-quantum secure cryptographic hybrid, that can provide the security, as well as the scalability and computational economy necessary if a system of this kind is to be considered for wide-scale adoption.

Problem Description:

In modern cryptographic systems, the security of key exchanges is increasingly threatened by advanced classical and emerging quantum attack vectors, many of which exploit weaknesses in randomness generation. Multi-party key exchange protocols that incorporate multiple independent sources of entropy provide a robust defense against these threats. By leveraging

contributions from diverse entropy providers, such as hardware RNGs, network entropy beacons, and distributed nodes, the protocol ensures high-quality, unbiased randomness. This approach mitigates risks associated with single-point entropy failures, state recovery attacks, and entropy manipulation, significantly enhancing the unpredictability of the shared key.

Such enhanced key exchanges are crucial for post-quantum security, as quantum adversaries can exploit weak or deterministic entropy with powerful algorithms like Grover's and Shor's. By distributing the entropy contributions, the attack surface is widened, making it infeasible for a quantum attacker to compromise the entire pool of randomness. Furthermore, the inclusion of multiple entropy sources provides resilience against side-channel attacks, precomputation attacks, impersonation attacks, and replay attempts, making the scheme well-suited for secure communications in critical infrastructure, federated applications, and next-generation decentralized systems. As the threat landscape evolves, integrating multiple dedicated sources of entropy into key exchange protocols will be vital for ensuring long-term, quantum-resistant security.

Design Requirements:

The distributed security system is computationally economical, with functions in the primary key exchange and tunnel being performed solely by symmetric cryptography.

That asymmetric functions be constrained to network control messaging, and device registration and initialization.

Certificates are used as a means to authenticate devices and the messages they produce during device initialization and network operations. Each device generates its own asymmetric signature key-pair, and retains the secret signing key. Each device uses the signature verification key to create a certificate which must be signed by the root security server, the trust anchor for the domain.

The network must be scalable, expensive asymmetric operations must be constrained to registration and key exchange with participating devices, after which operations become administrative, and devices use the minimal network and hardware resources to function.

The system must be designed to be a form of authenticated key distribution with no tolerance for failure. Any failure in the exchange between nodes in the scheme, whether it be authentication or the distribution of keys, packet values, or symmetric or asymmetric authentication failure, causes the failure of the exchange, and the collapse of the circuit.

1.1 Purpose

MPDC-I provides a distributed security provisioning across multiple autonomous devices.

The MPDC-I crypto-system, has been designed in such a way that:

- 1) The keying material used in the exchange is distributed across multiple autonomous devices, strongly mitigating the threat of MITM attacks.
- 2) Uses an advanced authentication system, across multiple core devices, and a hierarchal certificate scheme for authentication.

- 3) That the model must be scalable, computationally efficient, and provide strong security guarantees against a wide range of classical and quantum attacks.

2. Scope

This document describes the MPDC-I (Multi Party Domain Crypto-system - Interior Network) protocol, which is used to establish an encrypted and authenticated duplexed communications stream between a server and a host. The protocol is described in this document, and references to the example C implementation are available, including specific settings and software components necessary to its design.

The MPDC-I protocol is part of the MPDC protocol set; the interior protocol manages security at a domain level, whereas the MPDC-E protocol is the exterior protocol, that connects MPDC networks, authenticates internal and external certificates using a distributed trust model, and facilitates 'key injection' across trusted domains. The MPDC-E protocol is being developed, and will appear as a future publication with a separate protocol definition.

2.1 Application

The MPDC-I protocol is intended for institutions that implement secure communication streams used to encrypt and authenticate secret information exchanged between a server and a host. The network design, key exchange functions, authentication and encryption of messages, and control message exchanges between devices defined in this document must be considered as mandatory elements in the construction of an MPDC-I network. Components that are not necessarily mandatory, but are the recommended settings or usage of the protocol will be denoted by the key-words **SHOULD**. In circumstances where strict conformance to implementation procedures is required but not necessarily obvious, the key-word **SHALL** will be used to indicate compulsory compliance is required to conform to the specification, likewise warnings indicating changes to the specification that are prohibited will be notated with **SHALL NOT**.

3. References

3.1 Normative References

3.1.1 FIPS 202: SHA-3 Standard: Permutation-Based Hash and Extendable Output Functions: This standard specifies the SHA-3 family of hash functions, including SHAKE extendable-output functions. <https://doi.org/10.6028/NIST.FIPS.202>

3.1.2 FIPS 203: Module-Lattice-Based Key Encapsulation Mechanism (ML-KEM): This standard specifies ML-KEM, a key encapsulation mechanism designed to be secure against quantum computer attacks. <https://doi.org/10.6028/NIST.FIPS.203>

3.1.3 FIPS 204: Module-Lattice-Based Digital Signature Standard (ML-DSA): This standard specifies ML-DSA, a set of algorithms for generating and verifying digital signatures, believed to be secure even against adversaries with quantum computing capabilities. <https://doi.org/10.6028/NIST.FIPS.204>

3.1.4 NIST SP 800-185: SHA-3 Derived Functions: cSHAKE, KMAC, TupleHash, and ParallelHash: This publication specifies four SHA-3-derived functions: cSHAKE, KMAC, TupleHash, and ParallelHash. <https://doi.org/10.6028/NIST.SP.800-185>

3.1.5 NIST SP 800-90A Rev. 1: Recommendation for Random Number Generation Using Deterministic Random Bit Generators: This publication provides recommendations for the generation of random numbers using deterministic random bit generators. <https://doi.org/10.6028/NIST.SP.800-90Ar1>

3.1.6 NIST SP 800-108: Recommendation for Key Derivation Using Pseudorandom Functions: This publication offers recommendations for key derivation using pseudorandom functions. <https://doi.org/10.6028/NIST.SP.800-108>

3.1.7 FIPS 197: The Advanced Encryption Standard (AES): This standard specifies the Advanced Encryption Standard (AES), a symmetric block cipher used widely across the globe. <https://doi.org/10.6028/NIST.FIPS.197>

3.2 Multi Party Cryptographic References

3.2.1 Threshold Cryptography by Yvo Desmedt (1994)
Introduces threshold cryptography for secure, distributed cryptographic operations. <https://onlinelibrary.wiley.com/doi/10.1002/ett.4460050407>

3.2.2 Secure Computation with Minimal Interaction by Gilad Asharov, Yehuda Lindell, Thomas Schneider, and Michael Zohner (2012)

Proposes protocols for secure two-party computation with minimal interaction.

<https://eprint.iacr.org/2013/552.pdf>

3.2.3 Efficient Secure Two-Party Computation Using Symmetric Cut-and-Choose by Wenliang Du and Mikhail Atallah (2001)

Presents an efficient protocol for secure two-party computation using cut-and-choose.

3.2.4 SPDZ: An Efficient MPC Protocol for Dishonest Majority by Ivan Damgård, Valerio Pastro, Nigel Smart, and Sarah Zakarias (2012)

Describes the SPDZ protocol for efficient multi-party computation with dishonest majority.

<https://eprint.iacr.org/2011/535.pdf>

3.2.5 Overdrive: Making SPDZ Great Again by Marcel Keller, Emmanuela Orsini, and Peter Scholl (2018)

Presents optimizations to SPDZ for improved efficiency and practicality.

<https://eprint.iacr.org/2017/1230.pdf>

3.3 Standards and Initiatives

3.3.1 NISTIR 8214A: Towards NIST Standards for Threshold Schemes for Cryptographic Primitives: A Preliminary Roadmap

Provides a roadmap towards NIST standards for threshold cryptography schemes.

<https://csrc.nist.gov/publications/detail/nistir/8214a/final>

3.3.2 ISO/IEC 11770-5:2011: Information technology, Security techniques, and Key management, Part 5: Group key management

Defines procedures for key management in secure group communications.

<https://www.iso.org/standard/54527.html>

3.3.3 IETF RFC 9380: The Messaging Layer Security (MLS) Protocol

Specifies the MLS protocol for secure and scalable group communication.

<https://datatracker.ietf.org/doc/rfc9380/>

3.3.4 IEEE P1363.3: Standard for Identity-Based Cryptographic Techniques using Pairings

Defines identity-based cryptographic techniques leveraging pairings.

https://standards.ieee.org/standard/1363_3-2013.html

3.3.5 ISO/IEC 15946 Series: Cryptographic Techniques Based on Elliptic Curves

Specifies cryptographic techniques based on elliptic curve algorithms.

<https://www.iso.org/standard/56026.html>

4. Terms and Definitions

4.1 Cryptographic Primitives

4.1.1 Kyber

The Kyber asymmetric cipher and NIST Post Quantum Competition winner.

4.1.2 McEliece

The McEliece asymmetric cipher and NIST Round 3 Post Quantum Competition candidate.

4.1.3 Dilithium

The Dilithium asymmetric signature scheme and NIST Post Quantum Competition winner.

4.1.5 SPHINCS+

The SPHINCS+ asymmetric signature scheme and NIST Post Quantum Competition winner.

4.1.6 RCS

The wide-block Rijndael hybrid authenticated symmetric stream cipher.

4.1.7 SHA-3

The SHA3 hash function NIST standard, as defined in the NIST standards document FIPS-202; SHA-3 Standard: Permutation-Based Hash and Extendable-Output Functions.

4.1.8 SHAKE

The NIST standard Extended Output Function (XOF) defined in the SHA-3 standard publication FIPS-202; SHA-3 Standard: Permutation-Based Hash and Extendable-Output Functions.

4.1.9 KMAC

The SHA3 derived Message Authentication Code generator (MAC) function defined in NIST special publication SP800-185: SHA-3 Derived Functions: cSHAKE, KMAC, TupleHash and ParallelHash.

4.2 Network References

4.2.1 Bandwidth

The maximum rate of data transfer across a given path, measured in bits per second (bps).

4.2.2 Byte

Eight bits of data, represented as an unsigned integer ranged 0-255.

4.2.3 Certificate

A digital certificate, a structure that contains a signature verification key, expiration time, and serial number and other identifying information. A certificate is used to verify the authenticity of a message signed with an asymmetric signature scheme.

4.2.4 Domain

A virtual grouping of devices under the same authoritative control that shares resources between members. Domains are not constrained to an IP subnet or physical location but are a virtual group of devices, with server resources typically under the control of a network administrator, and clients accessing those resources from different networks or locations.

4.2.5 Duplex

The ability of a communication system to transmit and receive data; half-duplex allows one direction at a time, while full-duplex allows simultaneous two-way communication.

4.2.6 Gateway: A network point that acts as an entrance to another network, often connecting a local network to the internet.

4.2.7 IP Address

A unique numerical label assigned to each device connected to a network that uses the Internet Protocol for communication.

4.2.8 IPv4 (Internet Protocol version 4): The fourth version of the Internet Protocol, using 32-bit addresses to identify devices on a network.

4.2.9 IPv6 (Internet Protocol version 6): The most recent version of the Internet Protocol, using 128-bit addresses to overcome IPv4 address exhaustion.

4.2.10 LAN (Local Area Network)

A network that connects computers within a limited area such as a residence, school, or office building.

4.2.11 Latency

The time it takes for a data packet to move from source to destination, affecting the speed and performance of a network.

4.2.12 Network Topology

The arrangement of different elements (links, nodes) of a computer network, including physical and logical aspects.

4.2.13 Packet

A unit of data transmitted over a network, containing both control information and user data.

4.2.14 Protocol

A set of rules governing the exchange or transmission of data between devices.

4.2.15 TCP/IP (Transmission Control Protocol/Internet Protocol)

A suite of communication protocols used to interconnect network devices on the internet.

4.2.16 Throughput: The actual rate at which data is successfully transferred over a communication channel.

4.2.17 UDP (User Datagram Protocol)

A communication protocol that offers a limited amount of service when messages are exchanged between computers in a network that uses the Internet Protocol.

4.2.18 VLAN (Virtual Local Area Network)

A logical grouping of network devices that appear to be on the same LAN regardless of their physical location.

4.2.19 VPN (Virtual Private Network)

Creates a secure network connection over a public network such as the internet.

5. Protocol Description

The Multi-Party Domain Cryptosystem – Interior Protocol (MPDC-I) is a cryptographic protocol designed to facilitate secure communication between entities in a domain. It leverages a combination of public-key cryptography, symmetric cryptography, and certificate management to establish an encrypted tunnel between participating devices. MPDC-I is engineered with both classical and quantum-resistant security in mind, utilizing robust cryptographic primitives to ensure confidentiality, integrity, and authentication of an encrypted communications stream.

5.1 Objectives

The primary objectives of MPDC-I are:

1. **Establish Secure Communication Channels:** Use public-key cryptography, certificate management, and entropy injection to create secure communications channels between participating devices.
2. **Ensure Forward Secrecy and Post-Quantum Resistance:** Provide security against both classical and quantum attacks in key exchange operations.
3. **Flexibility and Scalability:** Adapt to various network environments, including IoT, enterprise, and critical infrastructure.
4. **Prevent Common Cryptographic Attacks:** Defend against man-in-the-middle (MITM), replay, and key compromise attacks while ensuring integrity and authenticity.
5. **Provide a scalable and efficient MPC scheme:** Create an Multi Party Cryptographic scheme that is highly scalable, relatively lightweight, and computationally efficient.

5.2 Key Components and Their Roles

MPDC operates with five key devices:

1. **Client:** Initiates communication and key exchanges with the MPDC enabled Application Server.
2. **MAS (MPDC Application Server):** Acts as the server managing communications with Clients. The MAS is an application server on the local network, this can be a file server, database server, or any other type of network resource used by Clients that requires a secure connection.
3. **Agent:** A trusted network device that injects entropy into the key exchange process.
4. **DLA (Domain List Agent):** The network authority managing device registration and certificate validation.
5. **RDS (Root Domain Security):** The root authority responsible for signing and managing device certificates.

5.2.1 Client

Role: An end-user network device that initiates secure communication with the MAS.

Functions:

- Generates a certificate and stores the secret signing key.
- The certificate is signed by the RDS, directly or by proxy through the DLA.
- Exchanges *master fragment keys (mfk)* with Agents and MAS servers, to facilitate fragment key encryption.
- Combines *key fragments* provided by the Agents along with the MAS fragment key, which are used to derive a set of secure session keys.
- Encrypts and decrypts messages using the session keys in a duplexed encrypted and authenticated tunnel.

5.2.2 MAS (Application Server)

Role: Central server managing secure communications with Clients.

Functions:

- Generates a certificate and stores the secret signing key.
- The certificate is signed by the RDS, directly or by proxy through the DLA.
- Validates Client certificates using the RDS root certificate.
- Communicates with the Agents to obtain key fragments.
- Derives the session key to securely interact with the Client.
- Encrypts and decrypts messages using the session keys in a duplexed encrypted and authenticated tunnel.

5.2.3 Agent

Role: Provides additional entropy to the key exchange process.

Functions:

- Generates a certificate and stores the secret signing key.
- The certificate is signed by the RDS, directly or by proxy through the DLA.
- Generates key fragments (entropy) for session key generation.
- Securely transmits key fragments to both the MAS and Client.
- Enhances the randomness and security of the session key.

5.2.4 DLA (Domain List Agent)

Role: Manages device registration and certificate validation.

Functions:

- Generates a certificate and stores the secret signing key.
- The certificate is signed by the RDS.
- Validates device certificates against the RDS certificate.
- Maintains a master list of trusted devices (network topology).
- Distributes certificates and updates to devices.

- Manages device certificate revocation and resignation.
- Handles topological queries from network devices.

5.2.5 RDS (Root Domain Security Server)

Role: Acts as the certificate authority for the network.

Functions:

- Generates and manages the root certificate (trust anchor).
- Signs device certificates to verify identity and authenticity.
- Can connect to the DLA enabling a certificate signing proxy function.

5.3 Network Initialization

5.3.1 Root Server Initialization

Root Certificate Generation:

- The RDS generates its signature key-pair (public/private keys).
- Creates a public root certificate containing its signature verification key, serial number, issuer, configuration set, version, and expiration period.
- Securely stores the private key used for signing.

5.3.2 DLA Initialization

Certificate Generation:

- The DLA generates its signature key-pair.
- Creates a public certificate and stores the secret signing key.
- The RDS signs the DLA's certificate, establishing it as a trusted entity.

Network Management:

- The DLA begins managing device registrations and maintaining the network topology.

5.3.3 Device Initialization (Agent, Client, MAS)

Certificate Generation and Signing:

- Each device generates its own signature key-pair and certificate.
- Certificates are signed by the RDS directly or by proxy via the DLA.
- The RDS signs each device's certificate, establishing trust.

Registration with DLA:

- Devices register with the DLA, which validates their certificates.
- Devices are added to the network topology maintained by the DLA.
- Devices build partial copies of the topology, with knowledge of only the devices with which they interact.

5.3.4 MAS and Agent Integration

MAS Integration:

- The MAS contacts the DLA to join the network.
- Receives a list of available Agents from the DLA.
- Establishes secure channels with each Agent through an asymmetric key exchange that exchanges *master fragment keys*.

Agent Integration:

- Agents exchange *master fragment keys* with Clients and MAS devices using an asymmetric key exchange.
- Agents establish secure communication with the MAS and Clients, using the *mfk* keys to encrypt key fragments.

5.3.5 Client Integration

Client Integration:

- The Client joins the network by registering with the DLA.
- Receives a list of available Agent and MAS servers.
- Exchanges certificates with Agent and MAS servers.
- Exchanges *mfk* keys with Agents and MAS servers.

5.4 Network Initialization

MPDC network devices are initialized in a sequence:

1. RDS – Trust anchor
2. DLA – Network management
3. Agents – Entropy provider
4. MAS – Application server
5. Clients – End user device

The root security server (RDS) signs the certificate of each device, either directly or once the DLA is initialized, through the DLA proxy signing feature.

Each device generates its own asymmetric signature verification/signing keypair. The public signature verification key is a member of the certificate that each device generates independently. Certificates and signing keys are the sole responsibility of the device itself, and only the originating device has knowledge of the secret signing key.

The master fragment encryption keys *mfk*, shared between the devices, is used to derive fragment encryption keys (*efk*), ephemeral keys which encrypt key fragments exchanged between devices. When the certificate expiration time is exceeded, the *mfk* becomes invalid and a new certificate and master fragment key must be exchanged.

The maximum expiration time set in a certificate must not exceed the root certificate expiration time.

When a certificate is signed by the root, the certificate is hashed, and the hash is signed by the root signing key. The root signed hash is added to the child certificate, as well as the root certificate serial number, and if the user defined expiration time exceeds that of the root, the expiration time is set to the root's expiration time. No device certificate can have an expiration time that exceeds the root certificate's expiration time. Once the root certificate has expired, devices on the network must renew their certificates, and rejoin the network.

Each exchange in MPDC, whether it is a network message, part of the key exchange, or traffic on the encrypted tunnel, all of these functions use a *packet valid-time* feature. This adds the UTC time in **seconds** to the packet header at the point of packet creation. If the time in the packet valid-time parameter received by the remote host exceeds the packet valid-time field by the **packet time threshold** (60 seconds by default), the message is deemed invalid and the circuit is torn down.

The packet creation timestamp and packet sequence number are added to the signature hash on network messages, where the packet message is hashed along with the valid-time timestamp and the packet sequence number, then signed by the devices asymmetric signing key.

During the tunnelling phase, the sequence number and packet creation time (*st*) are added to the *additional data* function of the symmetric cipher MAC used to encrypt and authenticate messages in the encrypted tunnel (the AEAD authenticated stream cipher RCS). In this way, message replay attacks are strongly mitigated, and all MPDC messaging is protected from attack schemes that use packet header tampering, message alteration, or re-transmission of packet data.

5.4.1 Root certificate creation

The Root Domain Security server generates a signature key-pair.

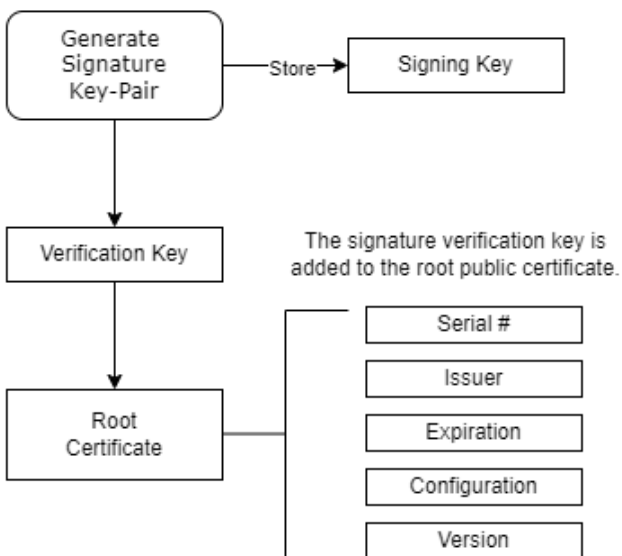

Figure 5.4.1 Root certificate generation.

The RDS generates a signature key-pair, stores the secret signing key, and adds the public signature verification key to the root certificate. The root certificate is made up of the following fields:

- The **signature verification key**, used to verify a root signature.
- The **issuer string**, identifies the certificate identity and formal name.
- The **serial number**, a unique 128-bit string used to identify the certificate.
- The **expiration time**, the valid *to* and *from* times, the time period during which the certificate is valid.
- The **configuration set** name, identifies the cryptographic primitives used by the key exchange from a set.
- The **version number**, the MPDC protocol version number.

The serial number and issuer fields identify the certificate and the originating device.

The expiration time is the starting time and expiration time of the certificate in UTC seconds from the epoch. All certificates signed by the root, expire when the root expires.

The algorithm set name identifies which cryptographic set is used in the implementation, this can be the combination of asymmetric cipher and signature scheme families; Kyber-Dilithium, McEliece-Dilithium, and McEliece-SPHINCS+, further subdivided by the parameter sets used by each cipher and signature scheme.

The version number ensures that local and remote versions are synchronized.

The RDS root certificate is distributed to every device on the network and installed during device initialization, cached by those devices and used to authenticate certificates signed by the root domain security server.

5.4.2 DLA Initialization

The Domain List Agent server generates a signature key-pair.

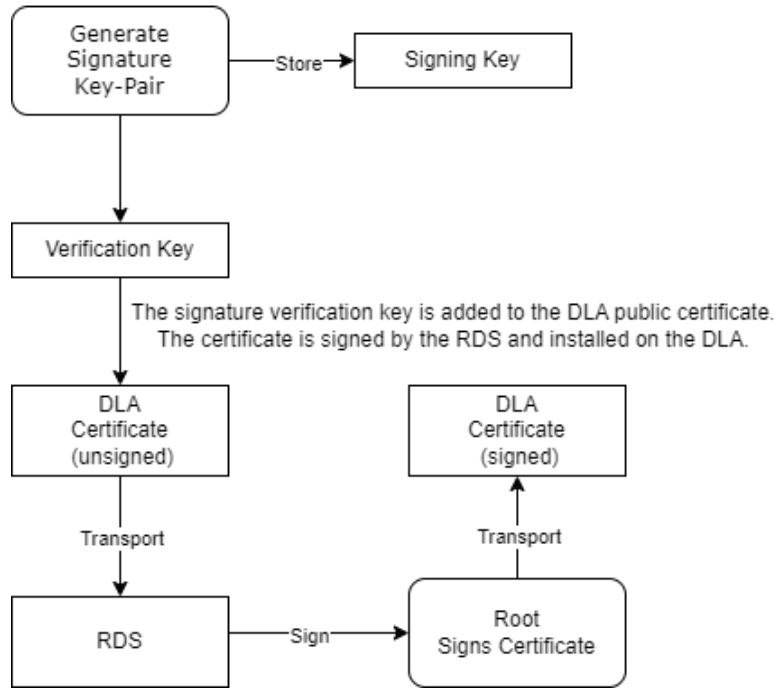

Figure 5.4.2a DLA certificate initialization

The DLA and all other child certificates have two additional parameters to the root certificate, the signature parameter which holds a copy of the RDS signed hash of the child certificate, and the root certificate serial number parameter.

Child certificate parameters:

- The **certificate signature**, generated by hashing the certificate, and signing the hash with the RDS signature key.
- The **root serial number** of the RDS server that signed this certificate.
- The **signature verification key**, used to verify a message signed by the corresponding signing key.
- The **issuer string**, identifies the certificate's origin identity and formal readable network name.
- The **serial number**, a unique 128-bit string used to identify the certificate.
- The **expiration time**, the valid *to* and *from* times, the time period during which the certificate is valid.
- The **configuration set** name, identifies the cryptographic primitives used by the key exchange from a set.
- The **version number**, the MPDC protocol version number.

Once the DLA certificate has been signed by the RDS server, the DLA server can be brought online and is ready to handle registration requests and other administrative duties.

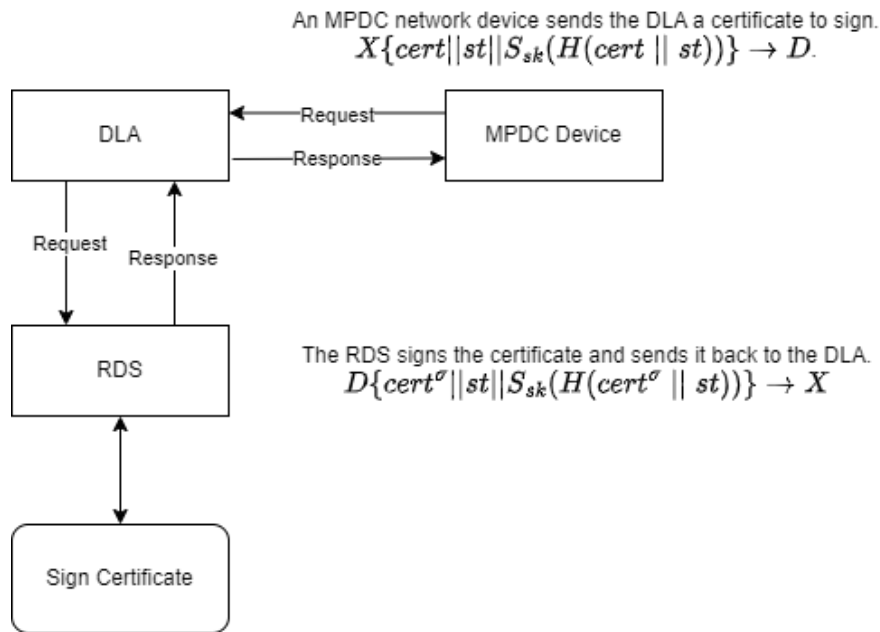

Figure 5.4.2b DLA proxy signing

The DLA certificate can be loaded onto the RDS to enable the proxy signing feature. The RDS server is deliberately isolated, it has only one message capability, and this is to remotely sign a certificate as requested *only* by the DLA server. The DLA can act as a proxy for the signing of device certificates, allowing the isolation of the root server from other network devices. The RDS stores the DLA certificate, and can only accept signing requests that have been issued and signed by the DLA.

5.4.3 Agent Initialization

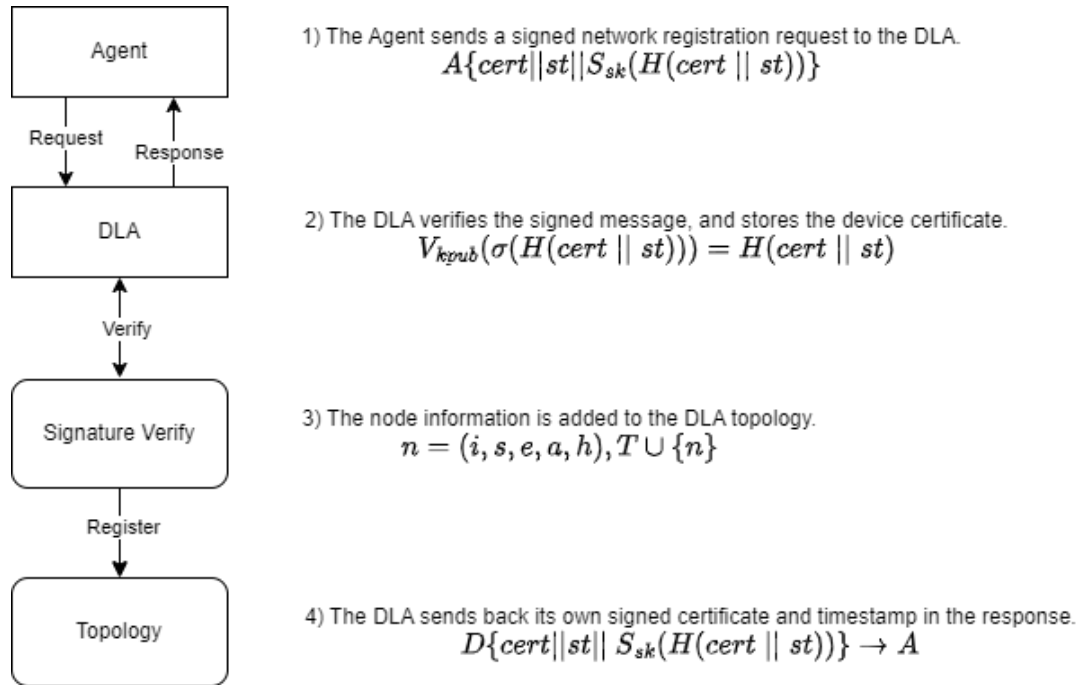

Figure 5.4.3 Agent network registration.

The Agent sends the DLA a registration request. The DLA verifies the signature field of the Agent certificate using the RDS public certificate. A hash of the certificate is compared to the signature hash to validate the certificate.

The registration request message has been signed by the Agent signing key, the message is authenticated, a message hash is generated and compared to the signature hash.

If the Agent certificate and the message have been validated, the certificate is stored, and the certificate is used to populate a topological node structure, which is added to the DLA topological database.

5.4.4 MAS Initialization

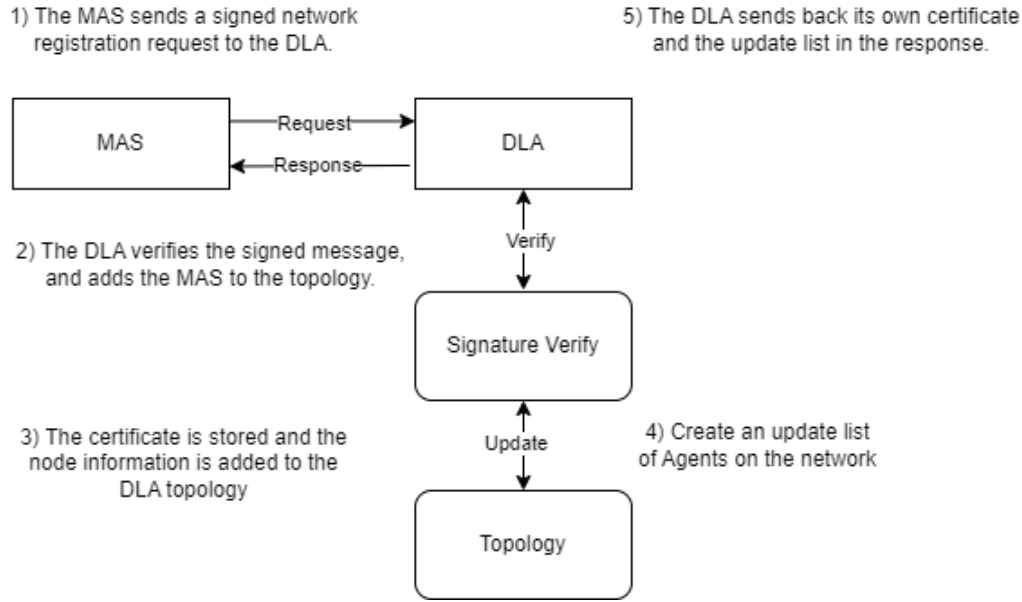

Figure 5.4.4a MAS network registration.

The MAS sends the DLA a registration request. The DLA verifies the signature field of the Agent certificate using the RDS public certificate. A hash of the certificate is compared to the signature hash to validate the certificate.

The registration request message has been signed by the MAS signing key, the message is authenticated, a message hash is generated and compared to the signature hash.

If the MAS certificate and the message have been validated, and the timestamp and sequence number are correct, the certificate is stored, and the certificate is used to populate a topological node structure, which is added to the DLA topological database.

The DLA assembles an update list for the MAS. The list contains the node information for every Agent on the network. The topological node contains all of the information that the MAS requires to contact and verify the Agent; IP address, the certificate serial number, issuer name, certificate expiration time, and the certificate hash. When the MAS contacts these devices and receives their certificates, the certificate hash value in the topological node is compared to a hash of the certificate. The serial number, issuer name, expiration time, and IP address must all match the values in the topological node received from the DLA.

The MAS sends an update request to each agent in the update list, containing the Agents serial number and a timestamp.

$$M\{rser \parallel st\} \rightarrow A$$

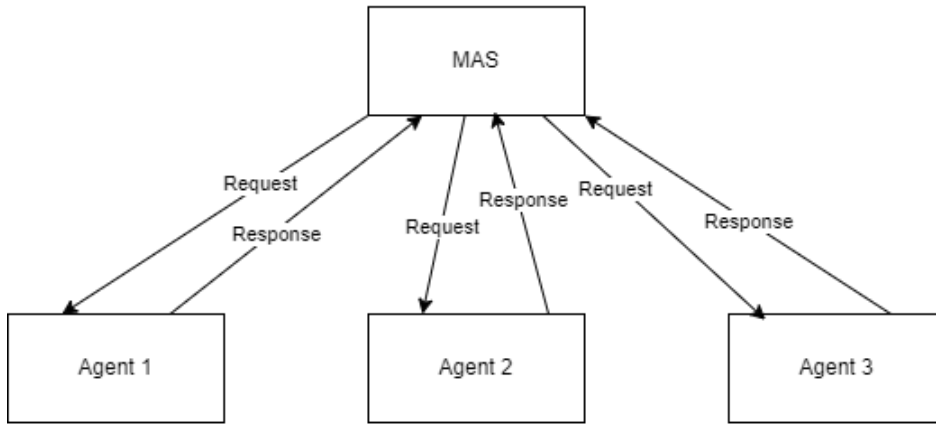

The Agents respond with their certificates, and a signed hash of the message.

$$A\{cert \parallel st \parallel S_{sk}(H(cert \parallel st))\} \rightarrow M$$

Figure 5.4.4b MAS agent update.

The MAS contacts each of the Agents in the DLA update list, and exchanges certificates. The certificates signatures are verified, and the certificate is hashed and compared to the signature hash. The verified certificates are stored on the MAS, and topological node entries for each Agent are added to the MAS topological database.

The MAS sends the Agent its certificate serial number, and the signed hash of the serial number and timestamp.

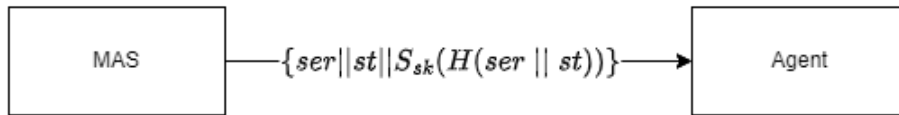

The Agent authenticates the message signature, generates a hash of the message and validates the message. The Agent generates an asymmetric cipher key pair, hashes the public key and the timestamp, signs the message, and sends the message back to the MAS.

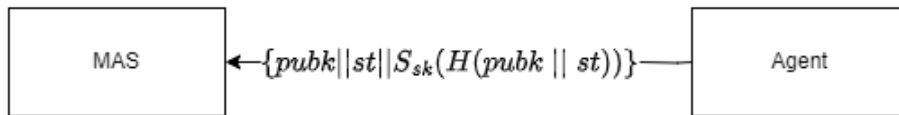

The MAS creates a shared secret *mfk*, encapsulates it using the public cipher key, hashes the ciphertext and timestamp, and sends the message to the Agent.

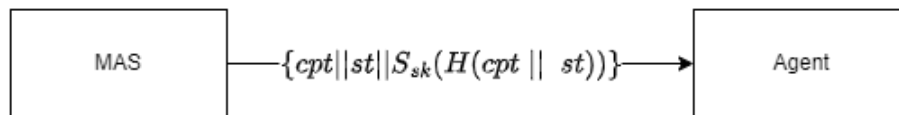

The Agent authenticates the message signature, generates a hash of the message and validates the message. The Agent decapsulates the shared secret, and if the key exchange succeeds, sends a key synchronized message to the MAS.

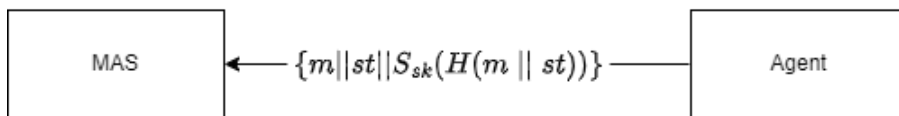

Figure 5.4.4c MAS to agent *mfk* exchange.

The MAS then sends each Agent a signed *mfk key exchange* request. The Agent generates an asymmetric cipher key-pair and timestamp, signs the public key and timestamp, and sends it to the MAS.

The MAS verifies the signed key and timestamp and encapsulates a shared secret, hashes the ciphertext and signs the hash. The signed ciphertext is sent back to the Agent, which verifies the signed hash, and decapsulates the shared secret.

The shared secret *mfk* key, is associated with the device certificate serial number of the relative remote device in an internal list, and stored on the Agent and MAS.

5.4.5 Client Initialization

The Client exchanges certificates and performs an mfk exchange with Agents and MAS servers.

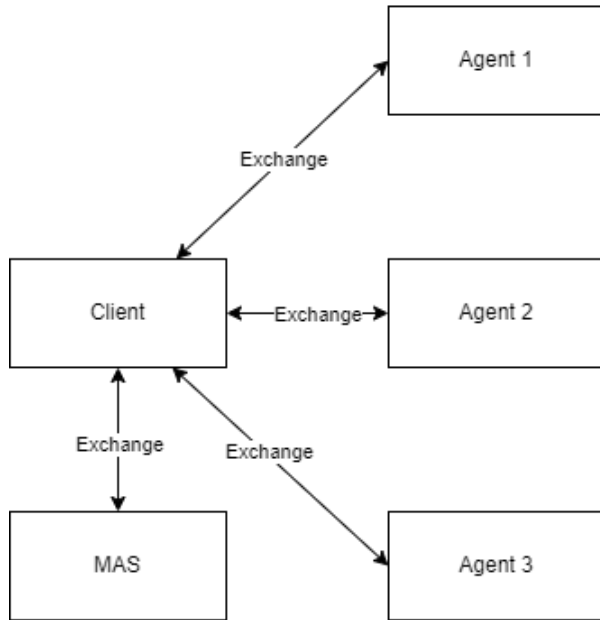

Figure 5.4.5 Client to MAS and Agent certificate and mfk exchange.

The Client registration undergoes an identical exchange of certificates and *mfk* keys with each Agent. The update list the DLA prepares for a Client also contains a list of MAS servers. The Client contacts each MAS server in the update list and exchanges certificates and master fragment keys.

Once the Clients have been initialized, the network is considered *synchronized*, and ready for encrypted tunnel connections between Clients and MPDC application servers.

5.5 Key Exchange and Encrypted Tunnel

The Client initiates a key exchange with an MPDC application server (MAS). The MAS server and the Client have previously exchanged master fragment keys, which are used to derive fragment encryption key (*efk*) used to encrypt pseudo-random fragments keys.

5.5.1 Fragment Collection Request

The Client sends a fragment collection request to the MAS.

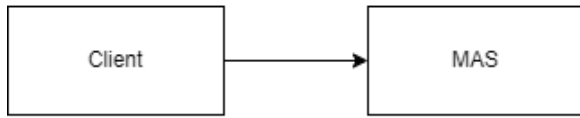

$$mefk = KDF(mfk || t || chash || mhash)$$

$$C\{ser || t || M_{mefk}(ser || t)\} \rightarrow M$$

Figure 5.5.1 Client to MAS connection request.

The Client creates a fragment collection request, the Client-to-MAS *mfk* key, a random token, and the Client and MAS certificate hashes are used to key a KDF (cSHAKE), and create a MAC key. The serial number and token are added to the message, and a MAC code is created by hashing the message and key.

5.5.2 MAS Fragment Request

The MAS connects to each Agent, requesting a fragment key.

$$M\{st || serm || tm || serc || tc\} \rightarrow A$$

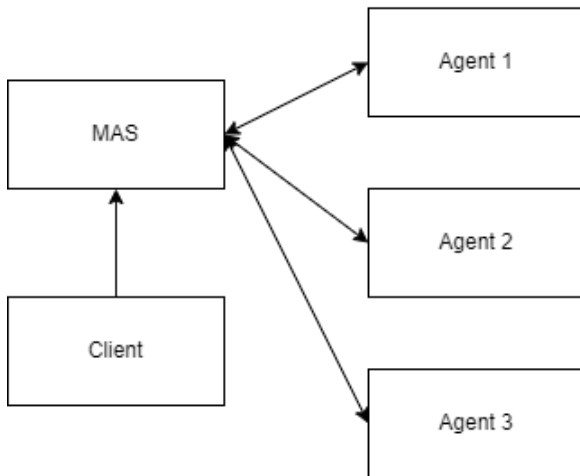

The Agent creates the fragment, copies it, and encrypts one copy using the MAS-to-Agent key, the other copy using the Client-to-Agent key.

Figure 5.5.2 Agent to MAS agent response.

The MAS connects to each Agent in the topology, and requests a fragment key. The Agents respond with a fragment key pairing, one copy encrypted with a fragment encryption key (*efk*) derived using the *mfk* shared between the MAS-to-Agent, the other copy encrypted with an *efk* key derived using the Client-to-Agent *mfk*.

5.5.3 MAS Key Generation

$$k_1, k_2, n_1, n_2 = KDF(fm \parallel fa_1, fa_2, \dots, fa_n)$$

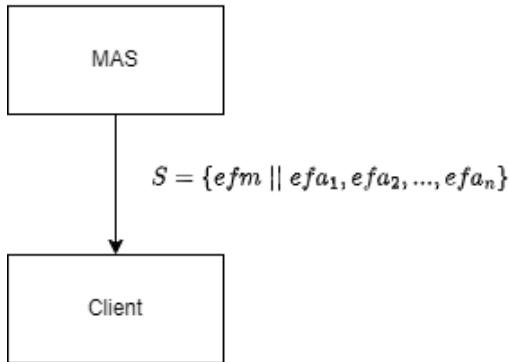

Figure 5.5.3 MAS to Client fragment transfer.

The MAS server decrypts its copy of the fragment received from each Agent, and generates a MAS-to-Client fragment key. The MAS encrypts the MAS-to-Client fragment using a fragment encryption key (*efk*) derived from the shared Client-to-MAS *mfk*, and bundles this key with the Agent fragment keys that were encrypted using Client-to-Agent *efk* derived from the *mfk* keys corresponding to each of the Agent responders.

The MAS sends the Client the encrypted fragment key set.

The MAS combines the fragments as input to a key derivation function (cSHAKE), and generates the MAS-to-Client session keys. The symmetric cipher (RCS) receive and transmit cipher instances are initialized, the tunnel is raised and ready to transmit data.

5.5.4 Tunnel Establishment

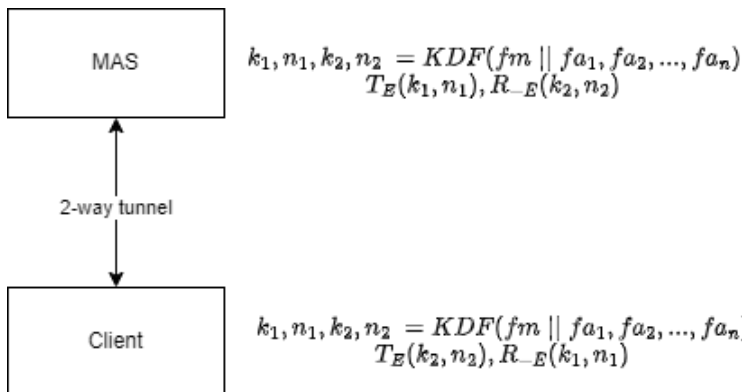

Figure 5.5.4 MAS to Client tunnel establishment.

The Client receives the encrypted fragment key bundle from the MAS. The Client derives the *efk* keys and decrypts the Agent key fragments, and derives the Client-to-MAS *efk* and decrypts the Client-to-MAS key fragment. The fragments are added to the KDF (cSHAKE) which generates the session keys for the transmit and receive channels of the encrypted tunnel. The symmetric cipher (RCS) instances are initialized, and the tunnel interfaces are raised and ready to transmit data.

6. Mathematical Description

MPDC uses various messages between devices to accomplish network tasks.

The DLA handles network control messaging, including certificate revocation, network convergence, certificate announcements, topological queries, registration and resignation messages.

Messages are also passed between Agents, MAS servers, and Clients, such as certificate updates, master fragment key exchanges, and fragment collection.

All messages are signed using the senders secret asymmetric signing key, and are verified by the receiving device using the senders' certificate. This not only guarantees the authenticity of the sender, but a packet creation time and sequence number are included in the message hash that is signed by the originating device, protecting the message from replay attacks.

This section contains a list of message functions used by MPDC-I, and their mathematical descriptions.

6.1 Announce Broadcast

Overview:

Network announce is an administrative event broadcast from the DLA. The DLA announces a new Agent to nodes on the network. It broadcasts the new agent's certificate, which is signed by the root, and signs the message with the DLA signing key. The receiving device validates the DLA signature and message hash, validates the root signature and parameters of the certificate, and checks that the packet timestamp is within the valid-time threshold. If the message is validated, the receiver adds the new device to its topology list, stores the certificate, and initiates a *master fragment key* exchange, trading shared secrets with the remote Agent device.

API:

- *mpdc_network_announce_broadcast()*
- *mpdc_network_announce_response()*

Applies to:

- Client
- DLA
- MAS

Mathematical Description:

Let:

- C_D^σ be the root signed certificate of device D .
- H be the hash function.
- H_{CS}^σ be the signed certificate and timestamp hash.
- K_{pri} be the private signing key.
- K_{pub} be the signature verification key.
- σ be an asymmetric signature.

- $Sign$ be the asymmetric signing function.
- st be the sequence number and valid-time timestamp.
- $Verify$ be the asymmetric signature verification function.

The broadcast includes the certificate and the signature:

$$H_{CS}^\sigma = \text{Sign}_{dlaK_{pri}}(H(C_D^\sigma \parallel st))$$

$$\text{Broadcast}(C_D^\sigma) = (C_D^\sigma \parallel H_{CS}^\sigma)$$

Devices receiving this broadcast will verify the signature using the DLA's public verification key:

$$\text{Verify}_{dlaK_{pub}}(H_{CS}^\sigma) = H(C_D^\sigma \parallel st)$$

If the broadcast message is validated, the certificate is added to the devices certificate store, and the device exchanges a *master fragment key* with the new Agent.

Proof of Security:

Correctness: The broadcast is correctly signed by the DLA, ensuring that any recipient can verify the signature using DLA public key. The verification succeeds if and only if $\sigma(H(C_D \parallel st))$ was produced using the DLA private key, providing assurance of authenticity.

Proof: Given the definition of digital signatures:

$$\sigma(H(C_D^\sigma \parallel st)) = \text{Sign}_{K_{pri}}(H(C_D^\sigma \parallel st))$$

The verification function computes:

$$\text{Verify}_{K_{pub}}(\sigma(H(C_D^\sigma \parallel st))) = H(C_D^\sigma \parallel st)$$

Since $\text{Verify}_{K_{pub}}$ is the inverse of $\text{Sign}_{K_{pri}}$, the signature is valid if it was signed by the matching private key.

Integrity: Since $H(C_D^\sigma \parallel st)$ is hashed and signed, any change to the certificate or signature would cause the verification to fail. The hash function used (e.g., SHAKE) is collision-resistant, ensuring that an attacker cannot forge C_D^σ or $\sigma(H(C_D^\sigma \parallel st))$.

Replay Protection: A timestamp and sequence number are included in the hash (st) and checked to ensure it is within a specified valid timeframe, so that broadcasts cannot be reused maliciously.

6.2 Converge Broadcast

Overview:

Network convergence is an administrative event called from the DLA. Each MAS server and Agent on the network is sent a copy of their topological node database entry. The serialized node entry for the remote device is hashed along with a timestamp and sequence number, and the hash is signed by the DLA and sent to the device.

The signature is verified by the device using the DLA's public certificate, the local node entry is serialized and hashed, and compared with the signed hash. If the hashes match, the entry in the DLA topological database is *synchronized*, if the entries do not match, the device serializes the current topological database entry and the certificate, signs them with the current signature key, which is signed by the root (RDS), and sends it back to the DLA. The DLA verifies the new certificate using the RDS certificate. The old entry is purged, a new topological entry is added to the database, and the new certificate is stored.

* Note that the proper procedure after a certificate update on a MAS or Agent, is to resign from the network, and then rejoin with a new certificate.

API:

- *mpdc_network_converge_request()*
- *mpdc_network_converge_response()*

Applies to:

- Agent
- DLA
- MAS

Mathematical Description:

Let:

- H_{TS}^σ be the signed hash of $H(T_D \parallel st)$ signed using D 's private key.
- H be the hash function.
- K_{pri} be the secret signing key.
- K_{pub} be the signature verification key.
- $Sign$ be the asymmetric signing function.
- st be the sequence number and valid-time timestamp.
- T_D be the topological node of device D .
- $Verify$ be the asymmetric signature verification function.

The converge broadcast request:

The DLA creates the converge request using the remote device's topological node, hashed with the timestamp and signed.

$$H_{TS}^\sigma = \text{Sign}_{dlaK_{pri}}(H(T_D \parallel st))$$

$$\text{Request}(T_D) = (T_D \parallel H_{TS}^\sigma)$$

The device verifies the DLA's signature.

$$\text{Verify}_{dlaKpub}(H_{TS}^\sigma) = H(T_D \parallel st)$$

The converge response:

The responding device signs the response message, and sends it to the DLA.

$$\sigma = \text{Sign}_{respKpri}(H(T_D \parallel st))$$

$$\text{Response}(T_R) = (T_R \parallel \sigma)$$

Proof of Security:

Correctness: The response is only generated if the request is valid. Both the request and the response signatures are verified using the public key of the respective device.

Proof: The request signature is:

$$\sigma(H(T_D \parallel st)) = \text{Sign}_{Kpri}(H(T_D \parallel st))$$

Upon receiving the request, the recipient checks the validity of the signature using:

$$\text{Verify}_{Kpub}(\sigma(H(T_D \parallel st))) = H(T_D \parallel st)$$

If the signature verification passes, the recipient knows the request is authentic. The node structure sent by the DLA, containing information about the remote device including certificate serial number, issuer, and expiration *to* and *from* times, is verified by the receiving device. If the node values match, the receiver signs its serialized node structure along with the timestamp and sequence number, and sends it back to the DLA as confirmation that the topology is aligned. If the values do not match, or the authentication or message is invalid, the receiver sends back an error message. If the DLA receives an error, or the connection times out, the remote node is removed from the DLA's topology, and the device's certificate is revoked, removing it from the topology list of every device on the network.

Integrity: The hash $H(T_D \parallel st)$ ensures that the certificate cannot be altered. Any tampering will result in a failed signature verification.

Replay Protection: A timestamp and sequence number are included in the hash $H(T_D \parallel ts)$ and checked to ensure that broadcasts cannot be reused maliciously.

6.3 FKey Request

Overview:

The FKey request is reserved for MPDC-E, it is used when the Inter Domain Gateway (IDG) is requesting a fragment key for a device on a remote network, as part of the cross-domain trusted entropy ‘borrowing’ that can be configured between trusted domains.

API:

- *mpdc_network_fkey_request()*
- *mpdc_network_fkey_response()*

Applies to:

- Agent
- IDG

Mathematical Description:

The key fragment request and response ensure secure transmission of key fragments.

Let:

- C_D^σ be the root signed certificate of the requesting device.
- F_D be the key fragment requested.
- H be the hash function (cSHAKE).
- H_{CS}^σ be the signed certificate and timestamp hash.
- $Sign$ be the asymmetric signing function.
- st be the sequence number and valid-time timestamp.
- $Verify$ be the asymmetric signature verification function.

The FKey request:

$$H_{CS}^\sigma = Sign_{idgKpri}(H(C_D^\sigma || st))$$

$$Request(C_D) = (C_D^\sigma || H_{CS}^\sigma)$$

The FKey response:

$$Verify_{idgKpub}(H_{CS}^\sigma) = H(F_D || st)$$

$$H_{FS}^\sigma = Sign_{idgKpri}(H(F_D || st))$$

$$Response(F_D) = (F_D || H_{FS}^\sigma)$$

This ensures the integrity and authenticity of the key fragment F_D .

Proof of Security:

Confidentiality: The key fragment F_D is securely transmitted and signed, ensuring that it cannot be intercepted or modified.

Proof: The key fragment is signed using the sender's private key:

$$\sigma(H(F_D \parallel st)) = \text{Sign}_{K_{\text{pri}}}(H(F_D \parallel st))$$

Upon receiving the fragment, the requesting device verifies:

$$\text{Verify}_{K_{\text{pub}}}(\sigma(H(F_D \parallel st))) = H(F_D \parallel st)$$

This ensures the key fragment's integrity and authenticity.

Replay Protection: A timestamp and sequence number are included in the hash $H(F_D \parallel ts)$ and checked to ensure that broadcasts cannot be reused maliciously.

6.4 Fragment Collection (Primary Client-to-MAS Tunnel)

Overview

The process begins when a Client sends a fragment key collection request to the MAS (MPDC enabled Application Server). This involves multiple symmetric-based key exchanges and cryptographic operations between the Client, MAS, and network Agents. The objective is to securely gather and validate key fragments from the Agents, derive shared session keys, and establish an encrypted tunnel between the Client and the MAS.

API:

- *mpdc_network_fragment_collection_request()*
- *mpdc_network_fragment_collection_response()*
- *mpdc_network_fragment_query_response()*

Applies to:

- Agent
- Client
- MAS

Step-by-Step Description

Client Request to MAS:

The Client initiates the fragment collection by sending a request to the MAS. This request includes:

- The Client's certificate serial number.
- A random token generated by the Client.

The MAS generates its own random token, and sends queries to every Agent in the topology.

Fragment Queries to Agents:

The MAS queries all Agents in the network by sending a fragment key request. Each query includes:

- The Client's certificate serial number and random token.
- The MAS's certificate serial number and random token.

If any Agent fails to respond or returns an error, the entire session is terminated.

Agent Dual Token Encryption:

The random token is copied and encrypted twice, one copy for the MAS the other for the Client:

- One copy is encrypted using a fragment encryption key (*efk*) derived from the MAS-to-Agent *mfk* fragment encryption session key.
- The other copy is encrypted using an *efk* derived from the Client-to-Agent *mfk* fragment encryption session key.

The MAS decrypts its copy of the fragment, and forwards the Client-to-Agent encrypted copies to the Client as a set. This fragment key-set includes a fragment generated by the MAS server and encrypted with the Client-to-MAS *mfk* derived fragment encryption key.

Deriving Session Keys:

The MAS decrypts the fragment keys it has received from the network Agents. The MAS generates a fragment key, and adds this key, and the decrypted Agent fragment keys to a KDF, which generates the session keys used to initialize symmetric cipher instances (RCS) for the transmit and receive channels of the Client-to-MAS tunnel.

The Client performs the same operations, decrypting the MAS fragment key, the Agent fragment keys, and using a KDF to derive the symmetric cipher session keys.

Mathematical Description:

Let:

- *cf* be the encrypted fragment key.
- *E*/*-E* be the encryption and decryption function.
- *efk* be the fragment encryption key.
- *frag* be the key fragment.
- *KDF* be the key derivation function (cSHAKE).
- *lhash* be the hash of the local certificate.
- *M* be the MAC function.
- *mfk* be the master fragment key, a shared master secret between two devices.

- $rhash$ be the hash of the remote certificate.
- ser be the device certificate serial number.
- tok be a random session token.
- st be the timestamp and sequence number.

The Client calculates the Client-to-MAS *fragment encryption key* (efk). The token is randomly generated, added with the Client-to-MAS shared *master fragment key* (mfk), the MAS certificate hash, and the Client certificate hash. The KDF generates a key used to initialize the MAC function, which MACs the request message.

$$efk_{mas}^{client} = \text{KDF}(mfk_{mas}^{client} || rhash_{mas} || lhash_{client} || tok_{client})$$

The Client sends the fragment collection request to the MAS containing its serial number and the random token. The serial number and token are MAC'd using the derived efk_{mas}^{client} fragment encryption key to initialize the MAC function. The ST_D message is the client's certificate serial number, the Client generated random token, and a MAC **tag** derived from the message and key. The packet creation timestamp and sequence number are also added to the MAC.

$$tag = \text{Me}f k_{mas}^{client}(ser || tok || st)$$

$$\text{Request}(ST_D) = (ser || tok || tag)$$

The MAS calculates the Client-to-MAS fragment encryption key, and checks the message MAC. If the MAC validates the message, and the timestamp and sequence number are correct, both Client and MAS have calculated their session fragment keys. If the MAC fails the MAS sends the Client an error message and the circuit is torn down.

$$\text{Me}f k_{mas}^{client}(ser || tok || st) = tag \Leftrightarrow \text{True}$$

The MAS connects to each agent in its topological map, and requests a key fragment. The MAS R_M request is composed of the MAS certificate serial number and random token, and the Client serial number and token is the R_C state.

$$R_M = (ser_{mas} || tok_{mas})$$

$$R_C = (ser_{client} || tok_{client})$$

The request is the pair of serial numbers and unique tokens for both MAS and Client, and the message MAC tag, derived from the message and efk_{agent}^{mas} key. The message is sent out to each Agent on the network, if the Agent is non-responding or returns an error, the key exchange is aborted.

$$tag = \text{Me}f k_{agent}^{mas}(R_M || R_C || st)$$

$$\text{Request}(R_M, R_C) = (R_M || R_C || tag)$$

Where each A_i is an agent server in the topology:

$$\text{Request}(R_M, R_C) \rightarrow \{A_1, A_2, \dots, A_n\}$$

Each Agent generates a random fragment key, makes a copy, and encrypts them both, the first copy is encrypted using the MAS-to-Agent fragment encryption key, the second using the Client-to-Agent fragment encryption key.

The first efk is derived from the MAS-to-Agent mfk , the MAS random token, and the Agent and MAS certificate hashes. This fragment key Encrypts the MAS copy of the key fragment. The efk_{agent}^{mas} creates two keys, the first is the fragment encryption key, the second is the key used to MAC the entire message, which will be verified by the MAS.

$$efk_{agent}^{mas} = \text{KDF}(mfk_{agent}^{mas} \parallel rhash_{mas} \parallel lhash_{agent} \parallel tok_{mas})$$

$$cf_1 = Eefk_{agent}^{mas}(frag)$$

The second fragment is encrypted using the Client-to-Agent derived key.

$$efk_{agent}^{client} = \text{KDF}(mfk_{agent}^{client} \parallel rhash_{client} \parallel lhash_{agent} \parallel tok_{client})$$

$$cf_2 = Eefk_{agent}^{client}(frag)$$

The ciphertext from both encrypted key sets are MAC'd and the MAC **tag** is added to the message. The MAC key is the second half of the (512-bit size) efk key.

$$tag = Mefk_{agent}^{mas}(cf_1 \parallel cf_2 \parallel st)$$

$$\text{Agent}(cf_1 \parallel cf_2 \parallel tag) \rightarrow \text{MAS.}$$

The MAS verifies the mac tag against the ciphertext, the sequence number and timestamp, and if they are correct, decrypts its portion of the key-set.

$$Mefk_{agent}^{mas}(cf_1 \parallel cf_2 \parallel hdr) = tag \Leftrightarrow \text{True}$$

The MAS copies the encrypted Client fragment keys and Agent serial numbers to a key-set. Once the MAS has collected keys from every Agent, it sends the set of encrypted Client-to-Agent keys back to the client, with each fragment encrypted with the respective Client-to-Agent efk .

Where:

- $fset$ is the set of agent fragment keys.
- as is the agent serial number.
- fc is the encrypted fragment key.

$$fset = \{ F_1(as_1 || fc_1), F_2(as_2 || fc_2), \dots, F_n(as_n || fc_n) \}$$

The encrypted key-set is sent to the Client, where like on the MAS, the serial number is used to look up the corresponding Agent *mfk*, derive the fragment encryption key, and verify and decrypt the fragment key sent by each agent, along with a key fragment shared between the MAS and the Client.

$$\text{For each } i \in \{ 1, 2, \dots, n \}, f_i = -E_{efk_{agent}^{client}}(cf_i)$$

All fragments are added to the hash to create a set of session keys used between the MAS and the Client to establish an encrypted tunnel. The fragment keys are added to the KDF input, including the fragment generated by the MAS for the Client:

$$k_1, k_2, n_1, n_2 = \text{KDF}(f_1, f_2, \dots, f_n)$$

This generates the session keys for the transmit and receive channels used to create a bi-directional encrypted tunnel between the MAS and the Client. The symmetric cipher instances (RCS) used to encrypt data on the receive and transmit channels of the encrypted tunnel are initialized on both the Client and MAS, and the tunnel interfaces are raised and ready to transmit data.

$$\text{Session} = \begin{cases} \text{Transmit}(Ek_1(n_1, data)) \\ \text{Receive}(-Ek_2(n_2, data)) \end{cases}$$

Proof of Security:

Correctness: Client and MAS servers share a secret exchanged during the *master fragment key* exchange. The Client and MAS also share unique secrets with every Agent on the network. This 256-bit secret key is combined with a random session token, and hashes of the local certificate and the remote certificate. The hash result is a fragment encryption key:

$$efk = \text{KDF}(mfk || rhash || lhash || tok)$$

The combination of certificate hashes will be unique between devices, this along with the random token which acts as a session nonce, ensures that every session derives unique fragment encryption keys. This *efk* is XOR'd with the *key fragment*; a 256-bit pseudo-random string generated by each agent.

$$cf = E_{efk}(frag)$$

Proof: Given a cryptographically strong key derivation function, specifically cSHAKE, the mixing of these inputs will produce a key-stream that is highly diffused and unique to each session. That key-stream mixed with the random fragment (XOR) will produce output that is indistinguishable from random, and highly resistant to differential analysis techniques.

Key fragments are input into the KDF, along with the Client-to-MAS session key. The KDF outputs keys and nonces for the two symmetric cipher instances, that will be the transmit and receive channels of the encrypted tunnel between the Client and the MAS.

$$k_1, k_2, n_1, n_2 = \text{KDF}(f_1, f_2, \dots, f_n)$$

Utilizing key fragments from Agents on the network, hardens the security of the server-to-client exchange. The injection of entropy into the key derivation, extends the mathematical hardness of differential analysis. By distributing the generation of the key across multiple autonomous devices on the network, impersonation, replay, and man-in-the-middle attacks become more problematic in proportion to the number of devices contributing to key generation.

6.5 Incremental Update

Overview:

The incremental update functions retrieve a devices certificate. When a device joins the network, the DLA sends a list of resources available for that device. When a MAS joins the network the DLA sends it a list of network Agents, when a Client joins the DLA sends a list of Agents and MAS servers.

The Client and MAS synchronize with devices on the list sent by the DLA, creating a topological database. The topology is a local list containing information about resources that the device uses on the network. A topological node is an element in the list that contains important information like the nodes IP address, issuer, expiration time, certificate hash and serial number. This information is used to connect to the device, request its certificate, verify the certificate, and interact with the device on the network.

The `mpdc_topology_node_state` structure defines the state information for a device within the MPDC topology. This includes details like network address, certificate information, and the device's designation.

Once the device has obtained the certificate and added the node to its topology, the device can exchange a shared secret between devices using the master fragment key (*mfk*) asymmetric key exchange.

During network registration, the Client and MAS device receive a list of resources they will use on the network.

The Client or MAS queries each node on this list, requesting the devices public certificate. The requestor uses the remote devices serial number S_D as the request message.

API:

- `mpdc_network_mfk_exchange_request()`
- `mpdc_network_mfk_exchange_response()`

Applies to:

- Agent
- Client
- MAS

Let:

- C_D^σ be the root signed certificate of device D .
- st be the sequence number and valid-time timestamp.
- σ be the asymmetric signature.
- H be the hash function.
- H_{CS}^σ be the signed certificate and timestamp hash.
- K_{pri} be the private signing key.
- K_{pub} be the signature verification key.
- ser_D be the requested certificate serial number.
- $Sign$ be the asymmetric signing function.
- st be the sequence number and packet creation timestamp.
- $Verify$ be the asymmetric signature verification function.

The incremental update request:

The device sends an incremental update request with the remote device certificate serial number.

$$\text{Request}(S_D) = (ser_D)$$

The responding device sends the serialized certificate, and a hash of the certificate and the packet headers valid-time timestamp and sequence number, signed with its secret signing key.

The incremental update response:

$$H_{CS}^\sigma = \text{Sign}_{respK_{pri}}(H(C_D^\sigma \parallel st))$$

$$\text{Response}(C_D^\sigma) = (C_D^\sigma \parallel H_{CS}^\sigma)$$

The certificate signature is verified and a hash of the certificate is compared to the signed hash, and the hash contained in the topological node entry. The certificate hash must match the hash stored in the node information sent by the DLA. If the certificate is validated, it is added to the devices certificate store.

$$\text{Verify}_{respK_{pub}}(H_{CS}^\sigma) = H(C_D^\sigma \parallel st)$$

Proof of Security:

Correctness: The response is only generated if the request is valid and the serial number in the request matches the responder's certificate serial number. The responder's certificate is verified by the requestor using the root public certificate. The response message signature is verified using the received public key of the respective device.

Proof: The response signature is:

$$\sigma(H(C_D^\sigma \parallel st)) = \text{Sign}_{K_{\text{pri}}}(\text{H}(C_D^\sigma \parallel st))$$

Upon receiving the request, the recipient checks the validity of the certificates' signature using:

$$\text{Verify}_{\text{root}K_{\text{pub}}}(\sigma(\text{H}(C_D))) = \text{H}(C_D)$$

The response message including the responder's certificate and valid-time timestamp are then verified using the validated responder's certificate.

$$\text{Verify}_{\text{dev}K_{\text{pub}}}(\sigma(\text{H}(C_D^\sigma \parallel st))) = \text{H}(C_D^\sigma \parallel st)$$

If the root signature verification passes, the certificate is authentic. The certificate is then used to authenticate that the message is valid and sent by the responding device. If any of these checks fail; root signature, responder message signature, hashes, sequence, packet creation valid-time, or the certificate hash comparison with the node hash value sent by the DLA, the certificate is rejected.

Integrity: The hash $\text{H}(C_D^\sigma \parallel st)$ ensures that the certificate cannot be altered. Any tampering will result in a failed signature verification.

Replay Protection: A timestamp and sequence number are included in the hash $\text{H}(C_D \parallel ts)$ and checked to ensure that the requests cannot be reused maliciously.

6.5 Master Fragment Key Exchange

Overview:

The master fragment key exchange, is an authenticated asymmetric key exchange, where a shared secret is exchanged between devices. A Client and a MAS exchange *master fragment keys (mfk)*, and both Client and MAS exchange master fragment keys with Agent servers.

API:

- *mpdc_network_mfk_exchange_request()*
- *mpdc_network_mfk_exchange_response()*

Applies to:

- Agent
- Client
- MAS

Mathematical Description:

Let:

- C_D^σ be the root signed certificate of device D .
- ct be the asymmetric cipher-text.
- Enc be the asymmetric encapsulation function.
- Dec be the asymmetric decapsulation function.
- H be the hash function.
- H_{CS}^σ be the signed certificate and timestamp hash.
- H_{ES}^σ be the signed asymmetric ciphertext and timestamp hash.
- H_{PS}^σ be the signed public cipher key and timestamp hash.
- $KGen$ be the asymmetric cipher key generation function.
- K_{pub} be the asymmetric signature public key.
- K_{pri} be the asymmetric signature private key.
- mfk be the master fragment key.
- pk be the asymmetric cipher public key.
- sk be the asymmetric cipher secret key.
- $Sign$ is the asymmetric signing function.
- ss be the shared secret.
- $Verify$ is the asymmetric verification function.

The requestor sends an exchange request to the device. The message contains the requestors serialized certificate, and a valid-time timestamp.

Note: Agents do not retain Client or MAS certificates.

$$H_{CS}^\sigma = \text{Sign}_{reqK_{pri}}(H(C_D^\sigma \parallel st))$$

$$\text{Request}(C_D^\sigma) = (C_D^\sigma \parallel H_{CS}^\sigma)$$

The responder verifies the certificates root signature.

$$\text{Verify}_{rootK_{pub}}(C_D^\sigma) = H(C_D)$$

The responder validates the requestors certificate and the valid-time timestamp are then verified using the validated responder's certificate.

$$\text{Verify}_{devK_{pub}}(H_{CS}^\sigma) = H(C_D^\sigma \parallel st)$$

The responder generates a keypair using the asymmetric cipher. It stores the private key, hashes and signs the public cipher key and valid-time timestamp, and sends it to the requestor.

$$pk, sk = \text{KGen}(\lambda, r)$$

$$H_{PS}^\sigma = \text{Sign}_{respK_{pri}}(H(pk \parallel st))$$

$$\text{Response}(pk) = (pk \parallel H_{PS}^\sigma)$$

The signed public key is sent to the requestor. The signature, hash, and timestamp are verified, and the requestor uses the public key to encapsulate a shared secret.

$$\text{Verify}_{respKpub}(H_{PS}^\sigma) = H(pk \parallel st)$$

$$ct = \text{Enc}_{pk}(ss)$$

The shared secret is retained by the requestor and is the *master fragment key*. The ciphertext is hashed along with the valid-time timestamp, and the hash is signed by the requestors signing key.

$$H_{ES}^\sigma = \text{Sign}_{reqKpri}(H(ct \parallel st))$$

$$\text{Request}(ct) = (ct \parallel H_{ES}^\sigma)$$

The responder verifies the message hash using the requestors public verification key, then compares the hash against the hashed ciphertext and timestamp.

$$\text{Verify}_{devKpub}(H_{ES}^\sigma) = H(ct \parallel st)$$

If the ciphertext is validated, the ciphertext is decrypted using the responders private cipher key.

$$ss = \text{Dec}_{sk}(ct)$$

Proof of Security:

Correctness: The key exchange consists of three steps:

- The requestor sends a signed hash of its certificate and timestamp to the responder.
- The responder signs a hash of the public cipher key and timestamp and sends it to the requestor.
- The requestor signs a copy of the ciphertext and timestamp and sends it to the responder.

Proof: Given the definition of digital signatures and the message m :

$$\sigma(H(m \parallel st)) = \text{Sign}_{Kpri}(H(m \parallel st))$$

The verification function computes:

$$\text{Verify}_{Kpub}(\sigma(H(m \parallel st))) = H(m \parallel st)$$

Since Verify_{Kpub} is the inverse of Sign_{Kpri} , the signature is valid if it was signed by the matching private key. The hash is generated from the message and compared to the signed hash for equality.

Integrity: Since $H(m \parallel st)$ is hashed and signed, any change to the certificate or signature would cause the verification to fail. The hash function used (e.g., SHAKE) is collision-resistant, ensuring that an attacker cannot forge C_D or $\sigma(H(m \parallel st))$.

Replay Protection: A timestamp and sequence number are included in the hash $H(m \parallel ts)$ and checked to ensure that broadcasts cannot be reused maliciously.

6.6 Registration Request

Overview:

An Agent registers with the DLA to join an MPDC network. The DLA verifies the agents certificate, then sends a copy of its own root-signed certificate, and adds the device to the topology.

API:

- *mpdc_network_register_request()*
- *mpdc_network_register_response()*

Applies to:

- Agent
- DLA

Mathematical Description:

Let:

- C_D^σ be the root signed device certificate.
- H be the hash function.
- H_{CS}^σ be the signed certificate and timestamp hash.
- K_{pri} be the private asymmetric signing key.
- K_{pub} be the public asymmetric verification key.
- Sign be the asymmetric signing function.
- σ be the signature.
- Verify be the asymmetric signature verification function.

The Agent requestor sends a *register request* to the device. The message contains the requestors serialized certificate, and a signed hash of the certificate and the valid-time timestamp.

The registration request:

$$H_{CS}^\sigma = \text{Sign}_{agentK_{pri}}(H(C_D^\sigma \parallel st))$$

$$\text{Request}(C_D^\sigma) = (C_D^\sigma \parallel H_{CS}^\sigma)$$

The DLA responder validates the requestors certificate and the valid-time timestamp are then verified using the validated responder's certificate.

$$\text{Verify}_{\text{rootKpub}}(\sigma(\text{H}(C_D))) = \text{H}(C_D)$$

$$\text{Verify}_{\text{agentKpub}}(\text{H}_{CS^\sigma}) = \text{H}(C_D^\sigma \parallel st)$$

The registration response:

The DLA hashes and signs its certificate and valid-time timestamp and sends it to the Agent.

$$\text{H}_{CS^\sigma} = \text{Sign}_{\text{dlaKpri}}(\text{H}(C_D^\sigma \parallel st))$$

$$\text{Response}(C_D^\sigma) = (C_D^\sigma \parallel \text{H}_{CS^\sigma})$$

The Agent verifies and stores the DLA certificate, generates a topological node for the DLA, and is registered on the network.

$$\text{Verify}_{\text{rootKpub}}(\sigma(\text{H}(C_D))) = \text{H}(C_D)$$

$$\text{Verify}_{\text{dlaKpub}}(\text{H}_{CS^\sigma}) = \text{H}(C_D^\sigma \parallel st)$$

6.7 Register Update Request

Overview:

When a Client or MAS registers with the DLA to join an MPDC network. The DLA verifies the devices certificate, then sends a list of topological nodes that are available for that device, a copy of its own root-signed certificate, and adds the device to the topology.

API:

- *mpdc_network_register_update_request()*
- *mpdc_network_register_update_response()*

Applies to:

- Client
- DLA
- MAS

Mathematical Description:

Let:

- C_D^σ be the root signed device certificate.

- H be the hash function.
- H_{CS}^σ be the signed certificate and timestamp hash.
- H_{CLS}^σ be the signed certificate, list, and timestamp hash.
- K_{pri} be the private asymmetric signing key.
- K_{pub} be the public asymmetric verification key.
- $list$ be the list of nodes.
- $Sign$ be the asymmetric signing function.
- σ be the signature.
- $Verify$ be the asymmetric signature verification function.

The requestor sends a *register update request* to the DLA. The message contains the requestors serialized certificate, and a signed hash of the certificate and the valid-time timestamp.

The registration update request:

$$H_{CS}^\sigma = \text{Sign}_{reqK_{pri}}(H(C_D^\sigma \parallel st))$$

$$\text{Request}(C_D^\sigma) = (C_D^\sigma \parallel H_{CS}^\sigma)$$

The DLA responder validates the requestors certificate root signature and the valid-time timestamp are then verified using the validated responder's certificate.

$$\text{Verify}_{rootK_{pub}}(\sigma(H(C_D))) = H(C_D)$$

$$\text{Verify}_{devK_{pub}}(H_{CS}^\sigma) = H(C_D^\sigma \parallel st)$$

The DLA generates a list of topological nodes for the device; MAS servers receive a list of Agent servers, and Clients receive the list of Agent and MAS servers.

The DLA hashes and signs the list, its certificate, and valid-time timestamp and sends it to the Agent.

The registration update response:

$list = \{ D_1, D_2, \dots D_n \}$ where D_i is a topological node.

$$H_{CLS}^\sigma = \text{Sign}_{dlaK_{pri}}(H(C_D^\sigma \parallel list \parallel st))$$

$$\text{Response}(C_D^\sigma \parallel list) = (C_D^\sigma \parallel list \parallel H_{CLS}^\sigma)$$

The requestor verifies and stores the DLA certificate, generates a topological node for the DLA, and is registered on the network. The requestor adds the list of nodes to the topological list, and will synchronize certificates with each device using the *incremental update* function, and then exchange master fragment keys using the *master fragment key exchange*. Once the device has the certificate and master fragment key of each device, its topology is considered *synchronized*.

$$\text{Verify}_{rootK_{pub}}(\sigma(H(C_D))) = H(C_D)$$

$$\text{Verify}_{dlaK_{pub}}(H_{CLS}^\sigma) = H(C_D^\sigma \parallel list \parallel st)$$

6.8 Remote Signing Request

Overview:

The root domain security (RDS) server only has a single networked function. Remote signing allows *only* the DLA to connect to the RDS, to act as a proxy for certificate signing. The DLA can sign certificates for devices on the network by connecting to the RDS, and forwarding the certificate to be signed. The RDS has a copy of the DLA certificate, allowing it to verify the signing request message.

API:

- *mpdc_network_remote_signing_request()*
- *mpdc_network_remote_signing_response()*

Applies to:

- DLA
- RDS

Mathematical Description:

Let:

- C_D be a device certificate.
- H be the hash function.
- H_{CS}^σ be the signed certificate and timestamp hash.
- K_{pri} be the private asymmetric signing key.
- K_{pub} be the public asymmetric verification key.
- Sign be the asymmetric signing function.
- σ be the signature.
- Verify be the asymmetric signature verification function.

The DLA sends a *remote signing request* to the RDS. The message contains the serialized certificate to be signed, and a signed hash of the certificate and the valid-time timestamp.

The remote signing request:

$$H_{CS}^\sigma = \text{Sign}_{dlaK_{pri}}(H(C_D \parallel st))$$

$$\text{Request}(C_D) = (C_D \parallel H_{CS}^\sigma)$$

The RDS validates the DLA's remote signing request signature, the certificate hash, and the valid-time timestamp.

$$\text{Verify}_{dlaKpub}(H_{CS}^\sigma) = H(C_D \parallel st)$$

The RDS signs the certificate, and sends it back to the DLA.

The remote signing response:

$$C_D^\sigma = \text{Sign}_{\text{root}Kpri}(H(C_D))$$

Response(C_D^σ)

The DLA verifies the root signature, and can now forward the certificate to the network device.

$$\text{Verify}_{\text{root}Kpub}(\sigma(H(C_D))) = H(C_D)$$

6.9 Resign Request

Overview:

A Client, MAS, or an Agent can resign from the network by sending a resign request to the DLA. The DLA sends out a revoke request broadcast removing the device's certificate and nodal information from every node on the network.

API:

- *mpdc_network_resign_request()*
- *mpdc_network_resign_response()*

Applies to:

- Agent
- Client
- DLA
- MAS

Mathematical Description:

Let:

- H be the hash function.
- H_{SS}^σ be the signed serial number and timestamp hash.
- K_{pri} be the private asymmetric signing key.
- K_{pub} be the public asymmetric verification key.
- $list$ be the list of nodes.
- Sign be the asymmetric signing function.
- σ be the signature.

- Verify be the asymmetric signature verification function.

The requestor sends a *resign request* to the DLA. The message contains the requestors certificate serial number, and a signed hash of the serial number and the valid-time timestamp.

The resignation request:

$$H_{SS}^{\sigma} = \text{Sign}_{devK_{pri}}(H(S_D \parallel st))$$

$$\text{Request}(S_D) = (S_D \parallel H_{SS}^{\sigma})$$

The DLA looks up the serial number in its topology, loads the device certificate and validates the signed message.

$$\text{Verify}_{devK_{pub}}(H_{SS}^{\sigma}) = H(S_D \parallel st)$$

The requesting device erases its topology, and must make a *register request* to the DLA to rejoin the network. The DLA sends a *revocation broadcast* to a subset of relevant nodes on the network.

6.10 Revoke Broadcast

Overview:

The revocation request is a broadcast message that instructs nodes on the network that a certificate has been revoked, and that device is to be removed from the network. Network members that receive this message, delete the devices certificate and remove it from the local topological database.

API:

- *mpdc_network_revoke_broadcast()*
- *mpdc_network_revoke_response()*

Applies to:

- Agent
- Client
- DLA
- MAS

Mathematical Description:

Let:

- H be the hash function.

- H_{SS}^σ be the signed serial number and timestamp hash.
- K_{pri} be the private asymmetric signing key.
- K_{pub} be the public asymmetric verification key.
- $list$ be the list of nodes.
- S_D be the device certificate serial number.
- $Sign$ be the asymmetric signing function.
- st be the sequence number and valid-time timestamp.
- σ be the signature.
- $Verify$ be the asymmetric signature verification function.

The DLA sends a *revoke request* to a subset of nodes on the network depending on the device type being revoked:

- Agent revocations are sent to Client and MAS devices.
- MAS revocations are sent to Agent and Client devices.
- Client revocations are sent to Agent and MAS devices.

The revocation message contains a signed copy of the device certificate serial number to be revoked.

$$H_{SS}^\sigma = \text{Sign}_{dlaK_{pri}}(\text{H}(S_D \parallel st))$$

$$\text{Request}(S_D) = (S_D \parallel H_{SS}^\sigma)$$

The DLA sends the revocation out to a list of devices.

$$L = \{ D_1, D_2, \dots, D_n \}$$

For each $i \in L = \text{Broadcast}(L_i, (S_D \parallel \sigma))$

6.11 Topological Query Request

Overview:

The Client-requestor sends the hashed and signed issuer string of a remote Client node and the local certificate serial number to the DLA.

Clients are not updated with each other's certificates during network registration. This is meant to scope topology information to the smallest number of nodes required for a given device.

Clients can connect to other Clients, by querying the DLA for a remote Clients node information. The Client sends the DLA the remote Client's network (issuer) name, and the DLA returns that Client's topological node information to the requestor.

The Client sends its serial number, and the remote nodes issuer string, which is composed of the network name, device name, and certificate extension. The query interface takes only the device name, which is resolved to the issuer string for the request. The DLA uses the certificate serial

number to load the requestors certificate, and verify the signature. The requesting Client receives the remote Clients node information, and uses it to synchronize certificates, and exchange master fragment keys.

API:

- *mpdc_network_topological_status_request()*
- *mpdc_network_topological_status_response()*

Applies to:

- Client
- DLA

Mathematical Description:

Let:

- H be the hash function.
- H_{SRS}^σ be the signed serial number, issuer name, and timestamp hash.
- H_{NS}^σ be the node and timestamp hash.
- I_D be the issuer string query.
- K_{pri} be the private asymmetric signing key.
- K_{pub} be the public asymmetric verification key.
- N_D be the serialized node.
- R_I be the remote device issuer name.
- S_D be the device serial number.
- $Sign$ be the asymmetric signing function.
- st be the sequence number and valid-time timestamp.
- σ be the signature.
- $Verify$ be the asymmetric signature verification function.

The Client sends a *topological query request* to the DLA. The message contains the requestors certificate number, the remote Client's issuer name, and a signed hash of the serial number, issuer name, and the valid-time timestamp.

$$H_{SRS}^\sigma = \text{Sign}_{clientK_{pri}}(H(S_D \parallel R_I \parallel st))$$

$$\text{Request}(I_D) = (S_D \parallel R_I \parallel H_{SRS}^\sigma)$$

The DLA responder validates the requestors signature, and the valid-time timestamp.

$$\text{Verify}_{clientK_{pub}}(H_{SRS}^\sigma) = H(I_D \parallel S_D \parallel st)$$

The DLA looks up the node in the topological database using the issuer string, hashes and signs the node, and sends it back to the requestor.

$$H_{NS}^{\sigma} = \text{Sign}_{dlaK_{pri}}(\text{H}(N_D \parallel st))$$

$$\text{Response}(N_D) = (N_D \parallel H_{NS}^{\sigma})$$

6.12 Topological Status Request

Overview:

The DLA sends a status request to the target Client, verifying it is online and available. It sends a signed copy of its certificate serial number in the message.

The remote Client receives the signed serial number for the remote node, verifies the hash, signature, and the serial number.

If the responder is available, it sends its signed serial number back to the DLA requestor.

The DLA verifies the message, and the function signals if the node is available for connect.

API:

- *mpdc_network_topological_query_request()*
- *mpdc_network_topological_query_response()*

Applies to:

- Client
- DLA

Mathematical Description:

Let:

- H be the hash function.
- H_{SS}^{σ} be the signed serial number and timestamp hash.
- I_D be the issuer string query.
- K_{pri} be the private asymmetric signing key.
- K_{pub} be the public asymmetric verification key.
- N_D be the serialized node.
- Sign be the asymmetric signing function.
- st be the sequence number and valid-time timestamp.
- σ be the signature.
- Verify be the asymmetric signature verification function.

The DLA sends a *topological status request* to the device. The message contains the DLA's certificate serial number, and a signed hash of the serial number and the valid-time timestamp.

$$H_{SS}^{\sigma} = \text{Sign}_{dlaK_{pri}}(\text{H}(S_D \parallel st))$$

$$\text{Request}(I_D) = (S_D \parallel H_{SS}^\sigma)$$

The responder validates the DLA's signature, serial number, and the valid-time timestamp.

$$\text{Verify}_{dlaK_{pub}}(H_{SS}^\sigma) = H(S_D \parallel st)$$

The responder then echoes back it's signed certificate serial number to the DLA if it is available.

$$H_{SS}^\sigma = \text{Sign}_{dlaK_{pri}}(H(S_D \parallel st))$$

$$\text{Response}(S_D) = (S_D \parallel H_{SS}^\sigma)$$

7. Security Analysis

MPDC is designed to provide robust security against a wide range of attacks, including classical and quantum threats. The protocol incorporates multiple layers of security measures to ensure confidentiality, integrity, authentication, and forward secrecy.

Defense Against Classical Attacks

7.1 Man-in-the-Middle (MITM) Attacks

Threat: An attacker intercepts and possibly alters communication between the Client and MAS, attempting to impersonate one or both parties.

Defense Strategies:

Certificate Validation:

- Both the Client and MAS use certificates signed by the RDS.
- Each party validates the other's certificate against the trusted root certificate.
- Any unauthorized certificate will fail validation.
- Impersonating a MAS would require impersonation of the entire Agent network, requiring each device's signing key be compromised.

Digital Signatures:

- Public keys are accompanied by digital signatures.
- Signatures are verified using the sender's public key.
- Altered public keys result in failed signature verification.

Mutual Authentication:

- Both parties authenticate each other using their respective key pairs and certificates.
- Prevents unauthorized entities from joining the communication.

7.2 Replay Attacks

Threat: An attacker reuses valid data transmissions to deceive a system into unauthorized actions.

Defense Strategies:

Nonces and Timestamps:

- Incorporate unique nonces and timestamps in messages.
- Ensures each message is fresh and cannot be replayed.

- Messages with old timestamps or used nonces are rejected.

Session Identifiers:

- Unique session IDs associated with each communication session.
- Prevents mixing of messages from different sessions.

7.3 Key Compromise Attacks

Threat: Compromise of a private key could allow an attacker to decrypt communications or impersonate a device.

Defense Strategies:

Multi-Party Key Contribution:

- Session key derivation involves key fragments from the Agent network.
- Compromising a single private key is insufficient without the Agent's fragment.

Regular Key Refresh:

- Session keys are refreshed periodically based on certificate expiration time.
- Limits the window of opportunity for attackers.

Forward Secrecy:

- Past session keys remain secure even if current private keys are compromised.
- Session keys are not derived solely from long-term private/public keys.

7.4 Entropy Injection and Randomness

Threat: Attacks exploiting weak or predictable keys due to insufficient randomness.

Defense Strategies:

Agent's Key Fragment:

- Provides high-quality entropy from an independent source.
- Enhances randomness in session key generation.

Multiple Entropy Sources:

- Combines entropy from Client, MAS, and Agent.
- Reduces the risk associated with any single point of failure.

Defense Against Quantum Attacks

Quantum computing poses a significant threat to classical cryptographic algorithms. MPDC addresses this by integrating quantum-resistant cryptographic primitives.

7.5 Post-Quantum Cryptography

Quantum Threat: Quantum algorithms like Shor's algorithm can break RSA, ECC, and other classical public-key systems.

Defense Strategies:

Quantum-Resistant Algorithms:

- Use lattice-based cryptography (e.g., Kyber, Dilithium) for public-key operations.
- Alternatively use code-based asymmetric cipher McEliece, and hash based signatures (SPHINCS+).
- Resistant to attacks from quantum computers, with a wide range of security options and parameter sets to accommodate different expectations of long-term security requirements.

Hash Functions:

- Employ SHAKE (SHA-3 variant) for hashing operations.
- Provides security against quantum attacks due to its collision and pre-image resistance even in a quantum context.

7.6 Entropy Injection and Randomness

Quantum Threat: Quantum computers could potentially simulate or predict key generation processes with insufficient entropy.

Defense Strategies:

Agent's Key Fragment:

- Injects additional entropy not predictable by quantum algorithms.
- Enhances the unpredictability of the session key.

Multi-Party Contribution:

- Session key depends on inputs from multiple parties.
- Increases computational difficulty for quantum adversaries.

Mathematical Proofs of Security

7.7 Correctness of Key Exchange

Shared Session Key:

Both MAS and Client compute:

Where:

- $fset$ is the set of fragment keys
- as is the agent serial number
- fc is the encrypted fragment key

Fragment set shared by MAS and Client:

$$fset = \{ F_1(as_1 || fc_1), F_2(as_2 || fc_2), \dots, F_n(as_n || fc_n) \}$$

Each fragment is decrypted.

$$\text{For each } i \in \{ 1, 2, \dots, n \}, f_i = -E_{efki_{agent}^{mas}}(cf_i)$$

Fragments are hashed to create a set of session keys used between the MAS and the Client to establish an encrypted tunnel. The fragment keys are added to the KDF input, including the fragment generated by the MAS for the Client:

$$k_1, k_2, n_1, n_2 = \text{KDF}(f_1, f_2, \dots, f_n)$$

Generates the session keys transmit and receive channels used to create an encrypted tunnel between the MAS and the Client.

$$\text{Session} = \begin{cases} \text{Transmit}(Ek_1(n_1, data)) \\ \text{Receive}(-Ek_2(n_2, data)) \end{cases}$$

Verification:

- Since all inputs are the same and verified, both parties derive the same session key.
- The distribution of keying material across multiple autonomous devices, ensures tamper-proof key derivation.
- That Client and MAS use different keys to decrypt each fragment, ensures the key fragments are not tampered with during transport.
- Entropy injected from multiple devices with different source random generators, vastly increases the mathematical hardness of differential analysis of the keying material.

7.8 Resistance to Attacks

Collision Resistance:

- Hash function is collision-resistant.
- Computationally infeasible to find different inputs that produce the same hash output.

Computational Difficulty:

- Without access to the private keys and the Agent's key fragment, attackers cannot compute the session key.
- Quantum algorithms do not efficiently solve lattice-based (Kyber, Dilithium), code-based (McEliece), or hash-based (SPHINCS+) cryptographic problems used in MPDC.

7.9 Forward Secrecy

Session-Specific Keys:

- Each session generates a new, unique session key.
- Session keys are not stored long-term.

Ephemeral Key Fragments:

- Agent's key fragments are unique per session and discarded after use.
- Compromise of long-term keys does not affect past session keys.

Attack Mitigation Strategies

7.10 Certificate Revocation

Certificate Revocation:

- DLA can broadcast a revocation message to all affected devices.
- Devices remove the certificate and topological node from the database.

Comparison with Other Protocols

Strengths of MPDC

Multi-Party Key Exchange:

- Involves multiple entities, enhancing security through distribution of security and authentication.
- Agent's entropy injection strengthens randomness.

Post-Quantum Readiness:

- Incorporates quantum-resistant algorithms.
- Future-proof against advancements in quantum computing.

Flexibility and Scalability:

- Adaptable to various network sizes and configurations.
- Suitable for IoT, enterprise, and critical infrastructure.

Conclusion

MPDC offers a robust cryptographic protocol that addresses both current and emerging security threats. Its design emphasizes secure communication through multi-party key exchange, leveraging contributions from the Client, MAS, and Agent to establish a secure session key. By integrating quantum-resistant cryptographic primitives and comprehensive attack mitigation strategies, MPDC ensures long-term security and resilience against sophisticated attacks.

The protocol's flexibility and scalability make it suitable for a wide range of applications, from IoT devices to enterprise networks. While it introduces additional complexity and reliance on multiple entities, the enhanced security benefits outweigh these challenges in environments where security is paramount.

8. Application Scenarios

A multi-party key exchange scheme that incorporates multiple dedicated sources of entropy enhances security by utilizing distributed randomness to establish a shared key. This model can be particularly advantageous in environments where strong and unpredictable entropy is crucial to prevent attacks that exploit weak randomness or deterministic behavior. Here are potential use cases and applications of such a system:

8.1 Enhanced Client-Server Key Exchange for Critical Infrastructure

Description: In scenarios involving critical infrastructure (e.g., power grids, water treatment facilities, military, and state applications), secure client-server communication is paramount. A multi-party key exchange augmented with multiple dedicated sources of entropy can involve various components of the infrastructure contributing entropy to the key generation process.

Use Case: During the key exchange, the client and server gather entropy from geographically separated sensors or entropy sources. This approach reduces the risk of entropy failures, increases randomness, and mitigates single-point vulnerabilities that could be exploited by attackers.

Benefits:

- Greater resilience against entropy-based attacks, including side-channel attacks.
- Mitigates the risk of predictable keys, which is crucial in long-term infrastructure deployments.
- Adds strong resistance against impersonation and man-in-the-middle attacks.
- Increased security against both classical and quantum adversaries by ensuring high-quality randomness.

8.2 Secure Multi-user Messaging Applications

Description: Multi-party key exchange with multiple entropy sources can be utilized in secure messaging applications where a shared group key needs to be established. Instead of relying solely on client-provided randomness, each participant (or dedicated entropy provider) contributes entropy to the key agreement.

Use Case: In a secure group chat application, users connect through a central server. The server coordinates a key exchange where each client contributes entropy, as well as an independent entropy provider (e.g., a trusted hardware random number generator or an entropy service).

Benefits:

- Guarantees high-quality randomness for the group key, reducing the risk of key compromise.
- Provides robustness against compromised clients or entropy providers, as no single entity can control the entire randomness pool.
- Improves forward secrecy and deniability, essential for secure messaging applications like Signal or WhatsApp.

8.3 Post-Quantum Secure Remote Shell Protocol

Description: In a remote shell protocol (similar to SSH but quantum-secure), using a multi-party key exchange with multiple entropy sources enhances the security of the session key generation process. Entropy can be injected from both the client device, server device, and additional entropy nodes or agents on the network.

Use Case: During the key exchange, the client, server, and a distributed entropy agent (e.g., a hardware security module or remote entropy service) each provide contributions. The combined entropy is used to derive session keys, ensuring they are resistant to prediction or manipulation.

Benefits:

- Stronger resistance against entropy manipulation or degradation attacks.
- Enhanced post-quantum security, as the key generation process integrates randomness from multiple independent sources.
- Suitable for highly sensitive environments, such as financial trading platforms or military communication systems.

8.4 Secure Federated Learning and Distributed Data Analysis

Description: In federated learning, multiple data providers (e.g., hospitals, financial institutions) collaborate to train a machine learning model without sharing raw data. A secure multi-party key exchange with diverse entropy sources can protect the communication channels used to aggregate local model updates.

Use Case: Each data provider injects its own entropy into the key exchange, ensuring that the shared model aggregation keys are random and unpredictable. A central coordinator aggregates these updates securely using the derived keys.

Benefits:

- Prevents data inference attacks that could arise from weak key generation.
- Enhances data confidentiality by ensuring that the shared keys have strong, unbiased randomness.
- Provides robustness against compromised participants or entropy failures in a decentralized network.

8.5 Quantum-secure Blockchain Consensus Protocols

Description: In blockchain and distributed ledger systems, consensus mechanisms (e.g., Proof of Stake, Byzantine Fault Tolerance) require secure communication channels for node-to-node messaging. A multi-party key exchange using multiple entropy sources can ensure secure key generation even in the presence of malicious nodes.

Use Case: Nodes participating in the consensus inject entropy into the key exchange, along with a separate entropy provider (e.g., a random beacon or oracle service). The resulting shared key secures node-to-node communication and ensures the integrity of the consensus process.

Benefits:

- Increases the unpredictability of the shared key, making it resistant to manipulation by malicious nodes.
- Supports post-quantum security, protecting the blockchain against future quantum attacks.
- Improves the robustness of consensus mechanisms, reducing the risk of double-spending or consensus failure.

Advantages of Using Multiple Dedicated Sources of Entropy

1. Reduced Risk of Entropy Attacks:

By distributing the entropy contribution among multiple independent sources, the risk of a single point of entropy failure (e.g., faulty hardware RNG, compromised software RNG) is minimized.

2. Mitigation of Bias and Predictability:

Each entropy source may have different characteristics and potential biases. Combining contributions from diverse sources helps mitigate any inherent biases and increases the overall quality of randomness.

3. Resilience Against Compromise:

If one of the entropy sources is compromised or controlled by an attacker, the randomness provided by the other sources can still ensure the unpredictability of the key, making attacks significantly harder.

4. Quantum Resistance:

A robust and diverse entropy pool enhances the security of the key exchange against quantum adversaries, who might otherwise exploit deterministic patterns in key generation.

5. Flexibility and Scalability:

The approach can be adapted to various network configurations, including client-server, peer-to-peer, and decentralized systems, making it a versatile solution for modern cryptographic applications.

In conclusion, multi-party key exchanges that leverage multiple sources of entropy provide enhanced security, reliability, and quantum resistance, making them an essential component of next-generation cryptographic systems. These schemes address the increasing demand for secure and scalable communication protocols in distributed and decentralized environments.

9. Internal Functions

9.1 MPDC Certificate API Documentation

9.1.1 Function: `mpdc_certificate_algorithm_decode`

Purpose: Decodes a protocol-set string into its enumerated form for internal use.

Parameters:

- `name` (Type: `const char*`): A string representing the protocol-set.

Returns: `mpdc_configuration_sets` - The protocol-set enumerator corresponding to the provided string.

9.1.2 Function: `mpdc_certificate_algorithm_enabled`

Purpose: Tests if a specific protocol-set is enabled on this system.

Parameters:

- `conf` (Type: `mpdc_configuration_sets`): The protocol-set enumerator.

Returns: `bool` - Returns true if the protocol-set is enabled.

9.1.3 Function: `mpdc_certificate_algorithm_encode`

Purpose: Encodes the protocol-set enumerator to a string format.

Parameters:

- `name` (Type: `char*`): The output protocol-set string.
- `conf` (Type: `mpdc_configuration_sets`): The protocol-set enumerator.

Returns: `void`

9.1.4 Function: `mpdc_certificate_child_are_equal`

Purpose: Compares two child certificates for equivalence.

Parameters:

- a (Type: const mpdc_child_certificate*): The first certificate.
- b (Type: const mpdc_child_certificate*): The second certificate.

Returns: bool - Returns true if the two certificates are equal.

9.1.5 Function: mpdc_certificate_child_copy

Purpose: Copies data from one child certificate to another.

Parameters:

- output (Type: mpdc_child_certificate*): The destination certificate for copied data.
- input (Type: const mpdc_child_certificate*): The source certificate to copy.

Returns: void

9.1.6 Function: mpdc_certificate_child_create

Purpose: Initializes a new child certificate with provided parameters.

Parameters:

- child (Type: mpdc_child_certificate*): A pointer to the empty child certificate.
- pubkey (Type: const uint8_t*): A pointer to the public signature key (size: QSMP_VERIFYKEY_SIZE).
- expiration (Type: const mpdc_certificate_expiration*): The certificate expiration time structure.
- address (Type: const char*): The certificate IP address string.
- issuer (Type: const char*): The certificate issuer string.
- designation (Type: mpdc_network_designations): The certificate designation type.

Returns: void

9.1.7 Function: mpdc_certificate_child_decode

Purpose: Decodes a child certificate string into a certificate structure.

Parameters:

- child (Type: mpdc_child_certificate*): A pointer to the child certificate to populate.
- enck (Type: const char[MPDC_CHILD_CERTIFICATE_STRING_SIZE]): The encoded key array.

Returns: bool - Returns true if the key decoded successfully.

9.1.8 Function: mpdc_certificate_child_deserialize

Purpose: Deserializes a child certificate from a serialized input array into a structure.

Parameters:

- child (Type: mpdc_child_certificate*): A pointer to the child certificate.
- input (Type: const uint8_t*): A pointer to the serialized certificate data.

Returns: void

9.1.9 Function: mpdc_certificate_child_encode

Purpose: Encodes a child certificate into a readable string format.

Parameters:

- enck (Type: char[MPDC_CHILD_CERTIFICATE_STRING_SIZE]): The buffer to store the encoded certificate.
- child (Type: const mpdc_child_certificate*): The certificate to encode.

Returns: size_t - The size of the encoded certificate string.

9.1.10 Function: mpdc_certificate_child_erase

Purpose: Deletes the data of a child certificate.

Parameters:

- child (Type: mpdc_child_certificate*): A pointer to the child certificate to erase.

Returns: void

9.1.11 Function: mpdc_certificate_child_file_to_struct

Purpose: Loads a child certificate from a file into a structure.

Parameters:

- fpath (Type: const char*): The file path to the serialized certificate.
- child (Type: mpdc_child_certificate*): A pointer to the child certificate structure to populate.

Returns: bool - Returns true on successful loading.

9.1.12 Function: mpdc_certificate_child_hash

Purpose: Generates a hash of a child certificate.

Parameters:

- output (Type: uint8_t*): The output buffer for the hash (size: MPDC_CERTIFICATE_HASH_SIZE).
- child (Type: const mpdc_child_certificate*): A pointer to the child certificate to hash.

Returns: void

9.1.13 Function: mpdc_certificate_child_is_valid

Purpose: Checks if a child certificate has a valid format.

Parameters:

- child (Type: const mpdc_child_certificate*): A pointer to the child certificate to validate.

Returns: bool - Returns true if the certificate format is valid.

9.1.14 Function: mpdc_certificate_child_message_verify

Purpose: Verifies a message signature using the child certificate.

Parameters:

- message (Type: uint8_t*): The buffer to store the verified message output.

- msglen (Type: size_t*): The length of the verified message.
- signature (Type: const uint8_t*): The signed message.
- siglen (Type: size_t): The length of the signed message.
- child (Type: const mpdc_child_certificate*): A pointer to the child certificate used for verification.

Returns: bool - Returns true if the message signature is verified.

9.1.15 Function: mpdc_certificate_child_serialize

Purpose: Serializes a child certificate into a byte array.

Parameters:

- output (Type: uint8_t*): The array to receive the serialized certificate (size: MPDC_CERTIFICATE_CHILD_SIZE).
- child (Type: const mpdc_child_certificate*): The child certificate to serialize.

Returns: void

9.1.16 Function: mpdc_certificate_child_struct_to_file

Purpose: Saves a child certificate structure to a file.

Parameters:

- fpath (Type: const char*): The file path where the certificate will be saved.
- child (Type: const mpdc_child_certificate*): A pointer to the child certificate structure to save.

Returns: bool - Returns true on successful saving.

9.1.17 Function: mpdc_certificate_designation_decode

Purpose: Decodes a network designation string into its enumerated form.

Parameters:

- sdsg (Type: const char*): The string representing the network designation.

Returns: mpdc_network_designations - The enumerated network designation.

9.1.18 Function: mpdc_certificate_designation_encode

Purpose: Encodes a network designation enumerator to string format.

Parameters:

- sdsg (Type: char*): The buffer to store the encoded network designation string.
- designation (Type: mpdc_network_designations): The network designation enumerator to encode.

Returns: size_t - The size of the encoded string.

9.1.19 Function: mpdc_certificate_expiration_set_days

Purpose: Sets expiration days for a certificate.

Parameters:

- expiration (Type: mpdc_certificate_expiration*): Pointer to the expiration structure to configure.
- start (Type: uint16_t): Number of days before the certificate becomes valid.
- duration (Type: uint16_t): Duration in days for the certificate validity.

Returns: void

9.1.20 Function: mpdc_certificate_expiration_set_seconds

Purpose: Sets expiration time in seconds for a certificate.

Parameters:

- expiration (Type: mpdc_certificate_expiration*): Pointer to the expiration structure to configure.
- start (Type: uint64_t): The starting second when the certificate is valid.
- period (Type: uint64_t): Duration in seconds for the certificate validity.

Returns: void

9.1.21 Function: mpdc_certificate_expiration_time_verify

Purpose: Verifies if a certificate's expiration time is valid against the current time.

Parameters:

- expiration (Type: const mpdc_certificate_expiration*): A pointer to the expiration structure of the certificate.

Returns: bool - Returns true if the certificate has not expired.

9.1.22 Function: mpdc_certificate_message_hash_sign

Purpose: Hashes a message and generates a signature for the hash.

Parameters:

- signature (Type: uint8_t*): Buffer for storing the generated signature.
- sigkey (Type: const uint8_t*): The private signing key used for signing.
- message (Type: const uint8_t*): The message to sign.
- msglen (Type: size_t): Length of the message.

Returns: size_t - The size of the generated signature.

9.1.23 Function: mpdc_certificate_root_compare

Purpose: Compares two root certificates for equivalence.

Parameters:

- a (Type: const mpdc_root_certificate*): The first root certificate.
- b (Type: const mpdc_root_certificate*): The second root certificate.

Returns: bool - Returns true if the two root certificates are equal.

9.1.24 Function: mpdc_certificate_root_create

Purpose: Creates a new root certificate with specified parameters.

Parameters:

- root (Type: mpdc_root_certificate*): Pointer to the root certificate structure.
- pubkey (Type: const uint8_t*): Public key for the certificate.
- expiration (Type: const mpdc_certificate_expiration*): Certificate expiration time structure.
- issuer (Type: const char*): Issuer name string.

Returns: void

9.1.25 Function: mpdc_certificate_root_decode

Purpose: Decodes a root certificate from an encoded string.

Parameters:

- root (Type: mpdc_root_certificate*): Pointer to the root certificate structure to populate.
- enck (Type: const char*): Encoded string representing the certificate.

Returns: bool - Returns true if decoding is successful.

9.1.26 Function: mpdc_certificate_root_deserialize

Purpose: Deserializes a root certificate from a byte array.

Parameters:

- root (Type: mpdc_root_certificate*): Pointer to the root certificate to populate.
- input (Type: const uint8_t*): Input array containing the serialized certificate data.

Returns: void

9.1.27 Function: mpdc_certificate_root_encode

Purpose: Encodes a root certificate into a readable string format.

Parameters:

- enck (Type: char*): Buffer to store the encoded certificate.
- root (Type: const mpdc_root_certificate*): Root certificate to encode.

Returns: size_t - The size of the encoded certificate string.

9.1.28 Function: mpdc_certificate_root_erase

Purpose: Deletes data from a root certificate.

Parameters:

- root (Type: mpdc_root_certificate*): Pointer to the root certificate to erase.

Returns: void

9.1.30 Function: mpdc_certificate_root_file_to_struct

Purpose: Loads a root certificate from a file into a structure.

Parameters:

- fpath (Type: const char*): Path to the file containing the serialized certificate.
- root (Type: mpdc_root_certificate*): Pointer to the root certificate structure to populate.

Returns: bool - Returns true on successful loading.

9.1.31 Function: mpdc_certificate_root_hash

Purpose: Generates a hash of a root certificate.

Parameters:

- output (Type: uint8_t*): Buffer to store the hash (size: MPDC_CERTIFICATE_HASH_SIZE).
- root (Type: const mpdc_root_certificate*): Pointer to the root certificate to hash.

Returns: void

9.1.32 Function: mpdc_certificate_root_is_valid

Purpose: Validates the format and structure of a root certificate.

Parameters:

- root (Type: const mpdc_root_certificate*): Pointer to the root certificate to validate.

Returns: bool - Returns true if the root certificate is valid.

9.1.33 Function: mpdc_certificate_root_serialize

Purpose: Serializes a root certificate into a byte array.

Parameters:

- output (Type: uint8_t*): Array to receive the serialized certificate (size: MPDC_CERTIFICATE_ROOT_SIZE).
- root (Type: const mpdc_root_certificate*): Pointer to the root certificate to serialize.

Returns: void

9.1.34 Function: mpdc_certificate_root_sign

Purpose: Signs a child certificate with the root certificate's signing key.

Parameters:

- child (Type: mpdc_child_certificate*): Pointer to the child certificate to sign.
- root (Type: const mpdc_root_certificate*): Pointer to the root certificate used for signing.
- rsigkey (Type: const uint8_t*): Pointer to the root signing key (QSMP_SIGKEY_ENCODED_SIZE).

Returns: size_t - The size of the signed certificate.

9.1.35 Function: mpdc_certificate_root_signature_verify

Purpose: Verifies a child certificate's signature using the root certificate.

Parameters:

- child (Type: const mpdc_child_certificate*): Pointer to the child certificate being verified.
- root (Type: const mpdc_root_certificate*): Pointer to the root certificate for verification.

Returns: bool - Returns true if the signature is verified successfully.

9.1.37 Function: mpdc_certificate_root_struct_to_file

Purpose: Saves a root certificate structure to a file.

Parameters:

- fpath (Type: const char*): Path to the file where the certificate will be saved.
- root (Type: const mpdc_root_certificate*): Pointer to the root certificate structure to save.

Returns: bool - Returns true on successful saving.

9.1.38 Function: mpdc_certificate_signature_generate_keypair

Purpose: Generates an asymmetric key-pair for signing and verification.

Parameters:

- keypair (Type: mpdc_signature_keypair*): Pointer to a container that will hold the generated key-pair.

Returns: void

9.1.39 Function: mpdc_certificate_signature_hash_verify

Purpose: Verifies a signature over a hashed message using the child certificate.

Parameters:

- signature (Type: const uint8_t*): Pointer to the signed hash.
- siglen (Type: size_t): Length of the signed hash.
- message (Type: const uint8_t*): Pointer to the message hash.
- msglen (Type: size_t): Length of the message hash.
- lcert (Type: const mpdc_child_certificate*): Pointer to the certificate used for verification.

Returns: bool - Returns true if the signature is verified successfully.

9.1.40 Function: mpdc_certificate_signature_sign_message

Purpose: Signs a message using an asymmetric private key.

Parameters:

- `signature` (Type: `uint8_t*`): Array to store the generated signature (MPDC_ASYMMETRIC_SIGNATURE_SIZE).
- `message` (Type: `const uint8_t*`): The message to be signed.
- `msglen` (Type: `size_t`): Length of the message.
- `prikey` (Type: `const uint8_t*`): Private key used for signing.

Returns: `size_t` - The length of the generated signature.

9.1.41 Function: `mpdc_certificate_signature_verify_message`

Purpose: Verifies a signed message using an asymmetric public key.

Parameters:

- `message` (Type: `const uint8_t*`): The message to verify.
- `msglen` (Type: `size_t`): Length of the message.
- `signature` (Type: `const uint8_t*`): The signature to verify.
- `siglen` (Type: `size_t`): Length of the signature.
- `pubkey` (Type: `const uint8_t*`): Public key used for verification.

Returns: `bool` - Returns true if the message is verified successfully.

9.2 Crypto.h

9.2.1 Function: `mpdc_crypto_decrypt_stream`

Purpose: Decrypts a stream of bytes.

Parameters:

- `output` (Type: `uint8_t*`): Array receiving the decrypted plain text.
- `seed` (Type: `const uint8_t*`): Secret seed array (MPDC_CRYPTO_SEED_SIZE).
- `input` (Type: `const uint8_t*`): The encrypted input array.
- `length` (Type: `size_t`): Number of bytes to decrypt.

Returns: `bool` - Returns true on success.

9.2.2 Function: `mpdc_crypto_encrypt_stream`

Purpose: Encrypts a stream of bytes.

Parameters:

- `output` (Type: `uint8_t*`): Array receiving the encrypted cipher text.
- `seed` (Type: `const uint8_t*`): Secret seed array (`MPDC_CRYPTO_SEED_SIZE`).
- `input` (Type: `const uint8_t*`): Plain text input array.
- `length` (Type: `size_t`): Number of bytes to encrypt.

Returns: `void`

9.2.3 Function: `mpdc_crypto_generate_application_keychain`

Purpose: Generates a secure key chain for application use.

Parameters:

- `seed` (Type: `uint8_t*`): Output array for the secret seed.
- `seedlen` (Type: `size_t`): Length of the seed array.
- `password` (Type: `const char*`): Password array.
- `passlen` (Type: `size_t`): Byte length of the password array.
- `username` (Type: `const char*`): Computer's user name.
- `userlen` (Type: `size_t`): Byte length of the user name array.

Returns: `void`

9.2.4 Function: `mpdc_crypto_generate_application_salt`

Purpose: Generates a unique application salt using OS sources.

Parameters:

- `output` (Type: `uint8_t*`): Array for the secret salt.
- `outlen` (Type: `size_t`): Length of the salt array.

Returns: `void`

9.2.5 Function: `mpdc_crypto_generate_hash_code`

Purpose: Hashes a message and writes it to an output array.

Parameters:

- output (Type: char*): Output array to receive the hash.
- message (Type: const char*): Pointer to the message array.
- msglen (Type: size_t): Length of the message array.

Returns: void

9.2.6 Function: mpdc_crypto_generate_mac_code

Purpose: Generates a message authentication code (MAC) for a message and writes it to an output array.

Parameters:

- output (Type: char*): Output array to receive the MAC.
- outlen (Type: size_t): Byte length of the output array.
- message (Type: const char*): Pointer to the message array.
- msglen (Type: size_t): Length of the message array.
- key (Type: const char*): Pointer to the key array.
- keylen (Type: size_t): Length of the key array.

Returns: void

9.2.7 Function: mpdc_crypto_hash_password

Purpose: Hashes a password and user name and writes it to an output array.

Parameters:

- output (Type: char*): Output array to receive the hash.
- outlen (Type: size_t): Byte length of the output array.
- username (Type: const char*): Computer's user name.
- userlen (Type: size_t): Byte length of the user name array.
- password (Type: const char*): Password array.
- passlen (Type: size_t): Byte length of the password array.

Returns: void

9.2.8 Function: mpdc_crypto_password_minimum_check

Purpose: Checks if a password meets a minimum security threshold.

Parameters:

- password (Type: const char*): Password array.
- passlen (Type: size_t): Byte length of the password array.

Returns: bool - Returns true if the password meets minimum requirements.

9.2.9 Function: mpdc_crypto_password_verify

Purpose: Hashes a password and user name and compares it to a stored hash value.

Parameters:

- username (Type: const char*): Computer's user name.
- userlen (Type: size_t): Byte length of the user name array.
- password (Type: const char*): Password array.
- passlen (Type: size_t): Byte length of the password array.
- hash (Type: const char*): Hash array for comparison.
- hashlen (Type: size_t): Byte length of the hash array.

Returns: bool - Returns true if the password and user name hash matches the stored value.

9.2.10 Function: mpdc_crypto_secure_memory_allocate

Purpose: Allocates a block of secure memory.

Parameters:

- length (Type: size_t): Byte length of the memory block to allocate.

Returns: uint8_t* - Pointer to the allocated memory or NULL if allocation fails.

9.2.11 Function: mpdc_crypto_secure_memory_deallocate

Purpose: Releases an allocated block of secure memory.

Parameters:

- block (Type: uint8_t*): Pointer to the memory block to deallocate.
- length (Type: size_t): Byte length of the allocated memory block.

Returns: void

9.3 API Documentation MPDC.h

9.3.1 Constants

MPDC_NETWORK_CLIENT_CONNECT

Enables client-to-client encrypted tunnels.

MPDC_NETWORK_MFK_HASH_CYCLED

Enables MFK key cycling (default).

MPDC_NETWORK_PROTOCOL_IPV6

Indicates that MPDC is using the IPv6 networking stack.

MPDC_EXTENDED_SESSION_SECURITY

Enables 512-bit security on session tunnels.

MPDC_ASYMMETRIC_CIPHERTEXT_SIZE

Defines the byte size of the asymmetric cipher-text array.

Value: QSC_KYBER_CIPHERTEXT_SIZE (variable, depending on the selected cipher).

MPDC_ASYMMETRIC_PRIVATE_KEY_SIZE

Defines the byte size of the asymmetric cipher private key array.

Value: QSC_KYBER_PRIVATEKEY_SIZE (variable, depending on the selected cipher).

MPDC_ASYMMETRIC_PUBLIC_KEY_SIZE

Defines the byte size of the asymmetric cipher public key array.

Value: QSC_KYBER_PUBLICKEY_SIZE (variable, depending on the selected cipher).

MPDC_ASYMMETRIC_SIGNATURE_SIZE

Defines the byte size of the asymmetric signature array.

Value: QSC_DILITHIUM_SIGNATURE_SIZE (variable, depending on the selected signature algorithm).

MPDC_ASYMMETRIC_SIGNING_KEY_SIZE

Defines the byte size of the asymmetric signing key array.

Value: QSC_DILITHIUM_PRIVATEKEY_SIZE (variable, depending on the selected signature algorithm).

MPDC_ASYMMETRIC_VERIFICATION_KEY_SIZE

Defines the byte size of the asymmetric verification key array.

Value: QSC_DILITHIUM_PUBLICKEY_SIZE (variable, depending on the selected signature algorithm).

MPDC_ACTIVE_VERSION

Defines the active version of MPDC.

Value: 1

MPDC_ACTIVE_VERSION_SIZE

Defines the size of the MPDC active version.

Value: 2

MPDC_APPLICATION_AGENT_PORT

Defines the default port number for the Agent.

Value: 37766

MPDC_AGENT_FULL_TRUST

Defines the full trust designation number.

Value: 1000001

MPDC_AGENT_MINIMUM_TRUST

Defines the minimum trust designation number.

Value: 1

MPDC_AGENT_NAME_MAX_SIZE

Defines the maximum agent name string length in characters. The last character must be a string terminator.

Value: 256

MPDC_AGENT_TWOWAY_TRUST

Defines the two-way trust designation number.

Value: 1000002

MPDC_APPLICATION_CLIENT_PORT

Defines the default port number for the MPDC Client.

Value: 37761

MPDC_APPLICATION_DLA_PORT

Defines the default port number for the DLA.

Value: 37762

MPDC_APPLICATION_IDG_PORT

Defines the default port number for the MPDC IDG.

Value: 37763

MPDC_APPLICATION_RDS_PORT

Defines the default port number for the RDS.

Value: 37764

MPDC_APPLICATION_MAS_PORT

Defines the default port number for the MAS.

Value: 37765

MPDC_CANONICAL_NAME_MINIMUM_SIZE

Defines the minimum size for a canonical name.

Value: 3

MPDC_CERTIFICATE_ADDRESS_SIZE

Defines the maximum IP address length.

Value: 22

MPDC_CERTIFICATE_ALGORITHM_SIZE

Defines the algorithm type size.

Value: 1

MPDC_CERTIFICATE_DEFAULT_PERIOD

Defines the default certificate validity period in seconds.

Value: 365 * 24 * 60 * 60 * 1000 (1 year)

MPDC_CERTIFICATE_DESIGNATION_SIZE

Defines the size of the child certificate designation field.

Value: 1

MPDC_CERTIFICATE_EXPIRATION_SIZE

Defines the certificate expiration date length.

Value: 16

MPDC_CERTIFICATE_HASH_SIZE

Defines the size of the certificate hash in bytes.

Value: 32

MPDC_CERTIFICATE_ISSUER_SIZE

Defines the maximum certificate issuer string length. The last character must be a string terminator.

Value: 256

MPDC_CERTIFICATE_LINE_LENGTH

Defines the line length of the printed MPDC certificate.

Value: 64

MPDC_CERTIFICATE_MAXIMUM_PERIOD

Defines the maximum certificate validity period in seconds.

Value: MPDC_CERTIFICATE_DEFAULT_PERIOD * 2

MPDC_CERTIFICATE_MINIMUM_PERIOD

Defines the minimum certificate validity period in seconds.

Value: 24 * 60 * 60 * 1000 (1 day)

MPDC_CERTIFICATE_SERIAL_SIZE

Defines the certificate serial number field length.

Value: 16

MPDC_CERTIFICATE_HINT_SIZE

Defines the size of the topological hint.

Value: MPDC_CERTIFICATE_HASH_SIZE + MPDC_CERTIFICATE_SERIAL_SIZE

MPDC_CERTIFICATE_SIGNED_HASH_SIZE

Defines the size of the signature and hash field in a certificate.

Value: MPDC_ASYMMETRIC_SIGNATURE_SIZE + MPDC_CERTIFICATE_HASH_SIZE

MPDC_CERTIFICATE_VERSION_SIZE

Defines the version ID size.

Value: 1

MPDC_CERTIFICATE_CHILD_SIZE

Defines the length of a child certificate.

Value: Calculated based on various field sizes.

MPDC_CERTIFICATE_IDG_SIZE

Defines the length of an IDG certificate.

Value: Calculated based on various field sizes.

MPDC_CERTIFICATE_ROOT_SIZE

Defines the length of a root certificate.

Value: Calculated based on various field sizes.

MPDC_CRYPTO_SYMMETRIC_KEY_SIZE

Defines the byte length of the symmetric cipher key.

Value: 32

MPDC_CRYPTO_SYMMETRIC_NONCE_SIZE

Defines the byte length of the symmetric cipher nonce.

Value: 32

MPDC_CRYPTO_SEED_SIZE

Defines the seed array byte size.

Value: 64

MPDC_CRYPTO_SYMMETRIC_TOKEN_SIZE

Defines the byte length of the token.

Value: 32

MPDC_CRYPTO_SYMMETRIC_HASH_SIZE

Defines the hash function output byte size.

Value: 32

MPDC_CRYPTO_SYMMETRIC_MAC_SIZE

Defines the MAC function output byte size.

Value: 32 or 64 if MPDC_EXTENDED_SESSION_SECURITY is enabled.

MPDC_CRYPTO_SYMMETRIC_SECRET_SIZE

Defines the shared secret byte size.

Value: 32

MPDC_CRYPTO_SYMMETRIC_SESSION_KEY_SIZE

Defines the session key security size.

Value: 32 or 64 if MPDC_EXTENDED_SESSION_SECURITY is enabled.

MPDC_DLA_CONVERGENCE_INTERVAL

Defines the interval between agent convergence checks in seconds.

Value: 86400 (24 hours)

MPDC_DLA_IP_MAX

Defines the maximum IP address length.

Value: 65

MPDC_DLA_PENALTY_MAX

Defines the maximum unreachable penalty before the DLA is deemed unreliable.

Value: 256

MPDC_DLA_REDUCTION_INTERVAL

Defines the time in milliseconds before a penalty is reduced for a flapping DLA.

Value: 1000000

MPDC_DLA_UPDATE_WAIT_TIME

Defines the interval in seconds between full topology updates.

Value: 604800 (7 days)

MPDC_ERROR_STRING_DEPTH

Defines the number of error strings.

Value: 26

MPDC_ERROR_STRING_WIDTH

Defines the maximum size in characters of an error string.

Value: 128

MPDC_MESSAGE_MAX_SIZE

Defines the maximum message size, including maximum signature and certificate sizes.

Value: 1400000

MPDC_MFK_EXPIRATION_PERIOD

Defines the MFK validity period in seconds.

Value: 5184000 (60 days)

MPDC_MINIMUM_PATH_LENGTH

Defines the minimum file path length.

Value: 9

MPDC_NETWORK_CONNECTION_MTU

Defines the MPDC packet buffer size.

Value: 1500

MPDC_NETWORK_DOMAIN_NAME_MAX_SIZE

Defines the maximum domain name length in characters. The last character must be a string terminator.

Value: 256

MPDC_NETWORK_MAX_AGENTS

Defines the maximum number of agent connections in a network.

Value: 1000000

MPDC_NETWORK_NODE_ID_SIZE

Defines the node identification string length.

Value: 16

MPDC_PERIOD_DAY_TO_SECONDS

Defines the number of seconds in a day.

Value: 86400

MPDC_SOCKET_TERMINATOR_SIZE

Defines the packet delimiter byte size.

Value: 1

MPDC_PACKET_ERROR_SIZE

Defines the packet error message byte size.

Value: 1

MPDC_PACKET_HEADER_SIZE

Defines the MPDC packet header size.

Value: 22

MPDC_PACKET_SUBHEADER_SIZE

Defines the MPDC packet sub-header size.

Value: 16

MPDC_PACKET_SEQUENCE_TERMINATOR

Defines the sequence number of a packet that closes a connection.

Value: 0xFFFFFFFFFUL

MPDC_PACKET_TIME_SIZE

Defines the byte size of the serialized packet time parameter.

Value: 8

MPDC_PACKET_TIME_THRESHOLD

Defines the maximum number of seconds a packet is valid.

Value: 600 (default; can be modified)

MPDC_NETWORK_TERMINATION_MESSAGE_SIZE

Defines the network termination message size.

Value: 1

MPDC_NETWORK_TERMINATION_PACKET_SIZE

Defines the network termination packet size, including the header and termination message.

Value: MPDC_PACKET_HEADER_SIZE +

MPDC_NETWORK_TERMINATION_MESSAGE_SIZE

Enums

9.3.2 mpdc_configuration_sets

Name	Description
mpdc_configuration_set_none	No algorithm identifier is set.
mpdc_configuration_set_dilithium1_kyber1_rcs256_shake256	The Dilithium-S1/Kyber-S1/RCS-256/SHAKE-256 algorithm set.
mpdc_configuration_set_dilithium3_kyber3_rcs256_shake256	The Dilithium-S3/Kyber-S3/RCS-256/SHAKE-256 algorithm set.
mpdc_configuration_set_dilithium5_kyber5_rcs256_shake256	The Dilithium-S5/Kyber-S5/RCS-256/SHAKE-256 algorithm set.
mpdc_configuration_set_dilithium5_kyber6_rcs512_shake512	The Dilithium-S5/Kyber-S6/RCS-256/SHAKE-256 algorithm set.
mpdc_configuration_set_sphincsplus1f_mceliece1_rcs256_shake256	The SPHINCS+-S1F/McEliece-

	S1/RCS-256/SHAKE-256 algorithm set.
mpdc_configuration_set_sphincsplus1s_mceliece1_rcs256_shake256	The SPHINCS+-S1S/McEliece-S1/RCS-256/SHAKE-256 algorithm set.
mpdc_configuration_set_sphincsplus3f_mceliece3_rcs256_shake256	The SPHINCS+-S3F/McEliece-S3/RCS-256/SHAKE-256 algorithm set.
mpdc_configuration_set_sphincsplus3s_mceliece3_rcs256_shake256	The SPHINCS+-S3S/McEliece-S3/RCS-256/SHAKE-256 algorithm set.
mpdc_configuration_set_sphincsplus5f_mceliece5_rcs256_shake256	The SPHINCS+-S5F/McEliece-S5a/RCS-256/SHAKE-256 algorithm set.
mpdc_configuration_set_sphincsplus5s_mceliece5_rcs256_shake256	The SPHINCS+-S5S/McEliece-S5a/RCS-256/SHAKE-256 algorithm set.
mpdc_configuration_set_sphincsplus5f_mceliece6_rcs256_shake256	The SPHINCS+-S5F/McEliece-S5b/RCS-

	256/SHAKE-256 algorithm set.
mpdc_configuration_set_sphincsplus5s_mceliece6_rcs256_shake256	The SPHINCS+-S5S/McEliece-S5b/RCS-256/SHAKE-256 algorithm set.
mpdc_configuration_set_sphincsplus5f_mceliece7_rcs256_shake256	The SPHINCS+-S5F/McEliece-S5c/RCS-256/SHAKE-256 algorithm set.
mpdc_configuration_set_sphincsplus5s_mceliece7_rcs256_shake256	The SPHINCS+-S5S/McEliece-S5c/RCS-256/SHAKE-256 algorithm set.

9.3.3 mpdc_network_designations

Name	Description
mpdc_network_designation_none	No designation was selected.
mpdc_network_designation_agent	The device is an agent.
mpdc_network_designation_client	The device is a client.
mpdc_network_designation_dla	The device is the DLA.
mpdc_network_designation_idg	The device is an inter-domain gateway.
mpdc_network_designation_mas	The device is a server.
mpdc_network_designation_remote	The device is a remote agent.
mpdc_network_designation_rds	The device is an RDS security server.
mpdc_network_designation_revoked	The device has been revoked.
mpdc_network_designation_all	Every server and client device on the network.

9.3.4 mpdc_network_errors

Name	Description
mpdc_network_error_none	No error was detected.
mpdc_network_error_accept_fail	The socket accept function returned an error.
mpdc_network_error_auth_failure	The cipher authentication has failed.
mpdc_network_error_bad_keep_alive	The keep alive check failed.
mpdc_network_error_channel_down	The communications channel has failed.
mpdc_network_error_connection_failure	The device could not make a connection to the remote host.
mpdc_network_error_decryption_failure	The decryption authentication has failed.
mpdc_network_error_establish_failure	The transmission failed at the kex establish phase.
mpdc_network_error_general_failure	The connection experienced an unexpected error.
mpdc_network_error_hosts_exceeded	The server has run out of socket connections.
mpdc_network_error_identity_unknown	The identity could not be verified.
mpdc_network_error_invalid_input	The input is invalid.
mpdc_network_error_invalid_request	The request is invalid.
mpdc_network_error_keep_alive_expired	The keep alive has expired with no response.
mpdc_network_error_keep_alive_timeout	The keepalive failure counter has exceeded the maximum limit.
mpdc_network_error_kex_auth_failure	The kex authentication has failed.
mpdc_network_error_key_not_recognized	The key-id is not recognized.
mpdc_network_error_key_has_expired	The certificate has expired.
mpdc_network_error_listener_fail	The listener function failed to initialize.
mpdc_network_error_memory_allocation	The server has run out of memory.
mpdc_network_error_packet_unsequenced	The packet was received out of sequence.
mpdc_network_error_random_failure	The random generator experienced a failure.
mpdc_network_error_ratchet_fail	The ratchet operation has failed.
mpdc_network_error_receive_failure	The receiver failed at the network layer.

mpdc_network_error_transmit_failure	The transmitter failed at the network layer.
mpdc_network_error_unknown_protocol	The protocol version is unknown.
mpdc_network_error_unsequenced	The packet was received out of sequence.
mpdc_network_error_verify_failure	The expected data could not be verified.

9.3.5 mpdc_network_flags

Name	Description
mpdc_network_flag_none	No flag was selected.
mpdc_network_flag_connection_terminate_request	The packet contains a connection termination message.
mpdc_network_flag_error_condition	The connection experienced an error message.
mpdc_network_flag_fragment_collection_request	The packet contains a server fragment collection request message.
mpdc_network_flag_fragment_collection_response	The packet contains an agent fragment collection response message.
mpdc_network_flag_fragment_request	The packet contains a server fragment key request message.
mpdc_network_flag_fragment_response	The packet contains an agent fragment key response message.
mpdc_network_flag_fragment_query_request	The packet contains a server fragment key query request message.
mpdc_network_flag_fragment_query_response	The packet contains an agent fragment key query response message.
mpdc_network_flag_incremental_update_request	The packet contains an incremental update request message.
mpdc_network_flag_incremental_update_response	The packet contains an incremental update response message.

mpdc_network_flag_register_request	The packet contains a join request message.
mpdc_network_flag_register_response	The packet contains a join response message.
mpdc_network_flag_register_update_request	The packet contains a join update request message.
mpdc_network_flag_register_update_response	The packet contains a join update response

9.3.6 mpdc_network_flags enumeration documentation

Name	Description
mpdc_network_flag_register_update_response	The packet contains a join update response message.
mpdc_network_flag_keep_alive_request	The packet contains a keep alive request.
mpdc_network_flag_keep_alive_response	The packet contains a keep alive response.
mpdc_network_flag_mfk_establish	The packet contains a server master fragment key establish message.
mpdc_network_flag_mfk_request	The packet contains a server master fragment key request message.
mpdc_network_flag_mfk_response	The packet contains a client MFK exchange response message.
mpdc_network_flag_mfk_verify	The packet contains a server master fragment key verify message.
mpdc_network_flag_network_announce_broadcast	The packet contains a topology announce broadcast.

mpdc_network_flag_network_converge_request	The packet contains a network convergence request message.
mpdc_network_flag_network_converge_response	The packet contains a network convergence response message.
mpdc_network_flag_network_converge_update	The packet contains a network convergence update message.
mpdc_network_flag_network_resign_request	The packet contains a network resignation request message.
mpdc_network_flag_network_resign_response	The packet contains a network resignation response message.
mpdc_network_flag_network_revocation_broadcast	The packet contains a certificate revocation broadcast.
mpdc_network_flag_network_signature_request	The packet contains a certificate signing request message.
mpdc_network_flag_system_error_condition	The packet contains an error condition message.
mpdc_network_flag_tunnel_connection_terminate	The packet contains a socket close message.
mpdc_network_flag_tunnel_encrypted_message	The packet contains an encrypted message.
mpdc_network_flag_tunnel_session_established	The exchange is in the established state.
mpdc_network_flag_tunnel_transfer_request	Reserved - The host has received a transfer request.
mpdc_network_flag_topology_query_request	The packet contains a topology query request message.
mpdc_network_flag_topology_query_response	The packet contains a topology query response message.
mpdc_network_flag_topology_status_request	The packet contains a topology status request message.

mpdc_network_flag_topology_status_response	The packet contains a topology status response message.
mpdc_network_flag_topology_status_available	The packet contains a topology status available message.
mpdc_network_flag_topology_status_synchronized	The packet contains a topology status synchronized message.
mpdc_network_flag_topology_status_unavailable	The packet contains a topology status unavailable message.
mpdc_network_flag_network_remote_signing_request	The packet contains a remote signing request message.
mpdc_network_flag_network_remote_signing_response	The packet contains a remote signing response message.

9.3.7 mpdc_protocol_errors

Name	Description
mpdc_protocol_error_none	No error was detected.
mpdc_protocol_error_authentication_failure	The symmetric cipher had an authentication failure.
mpdc_protocol_error_certificate_not_found	The node certificate could not be found.
mpdc_protocol_error_channel_down	The communications channel has failed.
mpdc_protocol_error_connection_failure	The device could not make a connection to the remote host.
mpdc_protocol_error_connect_failure	The transmission failed at the KEX connection phase.
mpdc_protocol_error_convergence_failure	The convergence call has returned an error.
mpdc_protocol_error_convergence_synchronized	The database is already synchronized.
mpdc_protocol_error_decapsulation_failure	The asymmetric cipher failed to decapsulate the shared secret.

mpdc_protocol_error_decoding_failure	The node or certificate decoding failed.
mpdc_protocol_error_decryption_failure	The decryption authentication has failed.
mpdc_protocol_error_establish_failure	The transmission failed at the KEX establish phase.
mpdc_protocol_error_exchange_failure	The transmission failed at the KEX exchange phase.
mpdc_protocol_error_file_not_deleted	The application could not delete a local file.
mpdc_protocol_error_file_not_found	The file could not be found.
mpdc_protocol_error_file_not_written	The file could not be written to storage.
mpdc_protocol_error_hash_invalid	The public-key hash is invalid.
mpdc_protocol_error_hosts_exceeded	The server has run out of socket connections.
mpdc_protocol_error_invalid_request	The packet flag was unexpected.
mpdc_protocol_error_certificate_expired	The certificate has expired.
mpdc_protocol_error_key_expired	The MPDC public key has expired.
mpdc_protocol_error_key_unrecognized	The key identity is unrecognized.
mpdc_protocol_error_listener_fail	The listener function failed to initialize.
mpdc_protocol_error_memory_allocation	The server has run out of memory.
mpdc_protocol_error_message_time_invalid	The network time is invalid or has substantial delay.
mpdc_protocol_error_message_verification_failure	The expected data could not be verified.
mpdc_protocol_error_no_usable_address	The server has no usable IP address assigned in the configuration.

mpdc_protocol_error_node_not_available	The node is not available for a session.
mpdc_protocol_error_node_not_found	The node could not be found in the database.
mpdc_protocol_error_node_was_registered	The node was previously registered in the database.
mpdc_protocol_error_operation_cancelled	The operation was cancelled by the user.
mpdc_protocol_error_packet_header_invalid	The packet header received was invalid.
mpdc_protocol_error_packet_unsequenced	The packet was received out of sequence.
mpdc_protocol_error_receive_failure	The receiver failed at the network layer.
mpdc_protocol_error_root_signature_invalid	The root signature failed authentication.
mpdc_protocol_error_serialization_failure	The certificate could not be serialized.
mpdc_protocol_error_signature_failure	The signature scheme could not sign a message.
mpdc_protocol_error_signing_failure	The transmission failed to sign the data.
mpdc_protocol_error_socket_binding	The socket could not be bound to an IP address.
mpdc_protocol_error_socket_creation	The socket could not be created.
mpdc_protocol_error_transmit_failure	The transmitter failed at the network layer.
mpdc_protocol_error_topology_no_agent	The topological database has no agent entries.

mpdc_protocol_error_unknown_protocol	The protocol string was not recognized.
mpdc_protocol_error_verification_failure	The transmission failed at the KEX verify phase.

Structs

9.3.8 mpdc_certificate_expiration

Name	Description
from	The starting time in seconds.
to	The expiration time in seconds.

9.3.9 mpdc_child_certificate

Name	Description
csig	The certificate's signed hash.
verkey	The serialized public verification key.
issuer	The certificate issuer.
serial	The certificate serial number.
rootser	The root certificate's serial number.
expiration	The from and to certificate expiration times.
designation	The certificate type designation.
algorithm	The algorithm configuration identifier.
version	The certificate version.

9.3.10 mpdc_idg_hint

Name	Description
chash	The remote certificate's signed hash.
rootser	The remote certificate's root serial number.

9.3.11 mpdc_idg_certificate

Name	Description
csig	The certificate's signed hash.

vkey	The serialized public verification key.
xcert	The serialized X509 certificate.
serial	The certificate serial number.
rootser	The root certificate's serial number.
hint	The certificate's topological hint.
issuer	The certificate issuer.
expiration	The from and to certificate expiration times.
designation	The certificate type designation.
algorithm	The algorithm configuration identifier.
version	The certificate version.

9.3.12 mpdc_connection_state

Name	Description
target	The target socket structure.
rxcp	The receive channel cipher state.
txcp	The transmit channel cipher state.
rxseq	The receive channel's packet sequence number.
txseq	The transmit channel's packet sequence number.
instance	The connection's instance count.
exflag	The network stage flag.

9.3.13 mpdc_keep_alive_state

Name	Description
target	The target socket structure.
etime	The keep alive epoch time.
seqctr	The keep alive packet sequence counter.
recd	The keep alive response received status.

9.3.14 mpdc_mfkey_state

Name	Description
serial	The MFK serial number.

mfk	The master fragment key.
------------	--------------------------

9.3.15 mpdc_network_packet

Name	Description
flag	The packet flag.
msglen	The packet's message length.
sequence	The packet sequence number.
utctime	The UTC time the packet was created in seconds.
pmessage	A pointer to the packet's message buffer.

9.3.16 mpdc_root_certificate

Name	Description
verkey	The serialized public key.
issuer	The certificate issuer text name.
serial	The certificate serial number.
expiration	The from and to certificate expiration times.
algorithm	The signature algorithm identifier.
version	The certificate version type.

9.3.17 mpdc_serialized_symmetric_key

Name	Description
keyid	The key identity.
key	The symmetric key.
nonce	The symmetric nonce.

9.3.18 mpdc_signature_keypair

Name	Description
prikey	The secret signing key.
pubkey	The public signature verification key.

9.3.19 mpdc_cipher_keypair

Name	Description
------	-------------

prikey	The asymmetric cipher private key.
pubkey	The asymmetric cipher public key.

Functions

9.3.20 Function: `mpdc_connection_close`

Purpose: Closes the network connection between hosts.

Parameters:

- `rsock` (Type: `qsc_socket*`): A pointer to the remote socket.
 - `err` (Type: `mpdc_network_errors`): The error message.
 - `notify` (Type: `bool`): Notify the remote host that the connection is closing.
-

9.3.21 Function: `mpdc_decrypt_packet`

Purpose: Decrypts a message and copies it to the message output.

Parameters:

- `cns` (Type: `mpdc_connection_state*`): A pointer to the connection state structure.
- `message` (Type: `uint8_t*`): The message output array.
- `msglen` (Type: `size_t*`): A pointer receiving the message length.
- `packetin` (Type: `const mpdc_network_packet*`): A pointer to the input packet structure.

Returns: `mpdc_network_errors` - The function error state.

9.3.22 Function: `mpdc_encrypt_packet`

Purpose: Encrypts a message and builds an output packet.

Parameters:

- `cns` (Type: `mpdc_connection_state*`): A pointer to the connection state structure.
- `packetout` (Type: `mpdc_network_packet*`): A pointer to the output packet structure.
- `message` (Type: `const uint8_t*`): The input message array.
- `msglen` (Type: `size_t`): The length of the message array.

Returns: `mpdc_network_errors` - The function error state.

9.3.23 Function: mpdc_connection_state_dispose

Purpose: Disposes of the tunnel state.

Parameters:

- cns (Type: mpdc_connection_state*): The tunnel connection state.
-

9.3.24 Function: mpdc_network_error_to_string

Purpose: Returns a pointer to a string description of a network error code.

Parameters:

- error (Type: mpdc_network_errors): The network error type.

Returns: const char* - A pointer to an error string or NULL.

9.3.25 Function: mpdc_protocol_error_to_string

Purpose: Returns a pointer to a string description of a protocol error code.

Parameters:

- error (Type: mpdc_protocol_errors): The protocol error type.

Returns: const char* - A pointer to an error string or NULL.

9.3.26 Function: mpdc_packet_clear

Purpose: Clears a packet's state.

Parameters:

- packet (Type: mpdc_network_packet*): A pointer to the packet structure.
-

9.3.27 Function: mpdc_packet_error_message

Purpose: Populates a packet structure with an error message.

Parameters:

- packet (Type: mpdc_network_packet*): A pointer to the packet structure.
 - error (Type: mpdc_protocol_errors): The error type.
-

9.3.28 Function: mpdc_packet_header_deserialize

Purpose: Deserializes a byte array to a packet header.

Parameters:

- header (Type: const uint8_t*): The header byte array to deserialize.
 - packet (Type: mpdc_network_packet*): A pointer to the packet structure.
-

9.3.29 Function: mpdc_packet_header_serialize

Purpose: Serializes a packet header to a byte array.

Parameters:

- packet (Type: const mpdc_network_packet*): A pointer to the packet structure to serialize.
 - header (Type: uint8_t*): The header byte array.
-

9.3.30 Function: mpdc_packet_set_utc_time

Purpose: Sets the local UTC seconds time in the packet header.

Parameters:

- packet (Type: mpdc_network_packet*): A pointer to a network packet.
-

9.3.31 Function: mpdc_packet_time_valid

Purpose: Checks the local UTC seconds time against the packet sent time for validity within the packet time threshold.

Parameters:

- packet (Type: const mpdc_network_packet*): A pointer to a network packet.

Returns: bool - Returns true if the packet was received within the valid-time threshold.

9.3.32 Function: mpdc_packet_to_stream

Purpose: Serializes a packet to a byte array.

Parameters:

- packet (Type: const mpdc_network_packet*): A pointer to the packet.
- pstream (Type: uint8_t*): A pointer to the packet structure.

Returns: size_t - The size of the byte stream.

9.3.33 Function: mpdc_stream_to_packet

Purpose: Deserializes a byte array to a packet.

Parameters:

- pstream (Type: const uint8_t*): The header byte array to deserialize.
 - packet (Type: mpdc_network_packet*): A pointer to the packet structure.
-

9.4 Network.h

9.4.1 mpdc_network_register_update_request_state

Name	Value	Description
address	const char*	The server address
lcert	const mpdc_child_certificate*	A pointer to the local certificate

list	mpdc_topology_list_state*	A pointer to the topology list
rcert	mpdc_child_certificate*	A pointer to the remote certificate
root	const mpdc_root_certificate*	A pointer to the root certificate
sigkey	const uint8_t*	A pointer to the secret signing key

9.4.2 mpdc_network_register_update_response_state

Name	Value	Description
csock	const qsc_socket*	A pointer to the connected socket
lcert	const mpdc_child_certificate*	A pointer to the local certificate
list	const mpdc_topology_list_state*	A pointer to the topology list
rcert	mpdc_child_certificate*	A pointer to the output remote certificate
root	const mpdc_root_certificate*	A pointer to the root certificate
sigkey	const uint8_t*	A pointer to the secret signing key

9.4.3 mpdc_network_mfk_request_state

Name	Value	Description
lcert	const mpdc_child_certificate*	A pointer to the local certificate
mfk	uint8_t*	A pointer to the master fragment key
rcert	const mpdc_child_certificate*	A pointer to the remote certificate
rnode	const mpdc_topology_node_state*	A pointer to the remote node structure
root	const mpdc_root_certificate*	A pointer to the root certificate
sigkey	const uint8_t*	A pointer to the secret signing key

9.4.4 mpdc_network_mfk_response_state

Name	Value	Description
------	-------	-------------

csock	const qsc_socket*	A pointer to the connected socket
ckp	mpdc_cipher_keypair	The asymmetric encryption key-pair
lcert	const mpdc_child_certificate*	A pointer to the local certificate
mfk	uint8_t*	A pointer to the master fragment key
rcert	mpdc_child_certificate*	A pointer to the remote certificate
root	const mpdc_root_certificate*	A pointer to the root certificate
sigkey	const uint8_t*	A pointer to the secret signing key

9.4.5 mpdc_network_remote_signing_request_state

Name	Value	Description
address	const char*	The RDS server address
rcert	mpdc_child_certificate*	A pointer to the remote certificate
root	const mpdc_root_certificate*	A pointer to the root certificate
sigkey	const uint8_t*	A pointer to the secret signing key

9.4.6 mpdc_network_remote_signing_response_state

Name	Value	Description
csock	qsc_socket*	A pointer to the connected socket
dcert	mpdc_child_certificate*	A pointer to the DLA certificate
rcert	mpdc_child_certificate*	A pointer to the remote certificate
root	const mpdc_root_certificate*	A pointer to the root certificate
sigkey	const uint8_t*	A pointer to the secret signing key

9.4.7 mpdc_network_resign_request_state

Name	Value	Description
address	const char*	The server address
inode	const mpdc_topology_node_state*	A pointer to the local node structure
sigkey	const uint8_t*	A pointer to the secret signing key

9.4.8 mpdc_network_resign_response_state

Name	Value	Description
list	const mpdc_topology_list_state*	A pointer to the topology list
rcert	mpdc_child_certificate*	A pointer to the remote certificate
rnode	mpdc_topology_node_state*	A pointer to the remote node structure
sigkey	const uint8_t*	A pointer to the secret signing key

9.4.9 mpdc_network_revoke_request_state

Name	Value	Description
designation	mpdc_network_designations	The node type designation
list	const mpdc_topology_list_state*	A pointer to the node database
rnode	const mpdc_topology_node_state*	A pointer to the remote node structure
sigkey	const uint8_t*	A pointer to the secret signing key

9.4.10 mpdc_network_revoke_response_state

Name	Value	Description
list	const mpdc_topology_list_state*	A pointer to the node database
rnode	mpdc_topology_node_state*	A pointer to the remote node structure
dcert	const mpdc_child_certificate*	A pointer to the DLA certificate

9.4.11 mpdc_network_topological_query_request_state

Name	Value	Description
dcert	const mpdc_child_certificate*	A pointer to the DLA certificate
dnode	mpdc_topology_node_state*	A pointer to the DLA node structure
issuer	const char*	A pointer to the query issuer string
rnode	mpdc_topology_node_state*	A pointer to the return remote node structure

serial	const uint8_t*	A pointer to the local serial number
sigkey	const uint8_t*	A pointer to the secret signing key

9.4.12 mpdc_network_topological_query_response_state

Name	Value	Description
csock	const qsc_socket*	The connected socket
ccert	const mpdc_child_certificate*	A pointer to the remote client's certificate
rnode	const mpdc_topology_node_state*	A pointer to the remote node structure
sigkey	const uint8_t*	A pointer to the secret signing key

9.4.13 Function: mpdc_network_announce_broadcast

Purpose: Announces a certificate using the DLA and broadcasts it to the network.

Parameters:

- state (Type: mpdc_network_announce_request_state*): The announce state structure.

Returns: mpdc_protocol_errors - The error code.

9.4.14 Function: mpdc_network_announce_response

Purpose: Processes an announce response message.

Parameters:

- state (Type: mpdc_network_announce_response_state*): The announce response state structure.
- packetin (Type: const mpdc_network_packet*): The input packet containing the announce request.

Returns: mpdc_protocol_errors - The error code.

9.4.15 Function: mpdc_network_application_to_port

Purpose: Retrieves the network designation from a port number.

Parameters:

- `tnode` (Type: `mpdc_network_designations`): The target network designation type.

Returns: `uint16_t` - The port number, or zero if the node type is invalid.

9.4.16 Function: `mpdc_network_broadcast_message`

Purpose: Broadcasts a message to a node type on the network.

Parameters:

- `list` (Type: `const mpdc_topology_list_state*`): A pointer to the topology list.
- `message` (Type: `const uint8_t*`): The message to send.
- `msglen` (Type: `size_t`): The length of the message.
- `tnode` (Type: `mpdc_network_designations`): The target node-type designation.

Returns: `void`

9.4.17 Function: `mpdc_network_certificate_verify`

Purpose: Verifies a certificate's format and root signature.

Parameters:

- `ccert` (Type: `const mpdc_child_certificate*`): The child certificate.
- `root` (Type: `const mpdc_root_certificate*`): The root certificate.

Returns: `mpdc_protocol_errors` - The error code.

9.4.18 Function: `mpdc_network_connect_to_address`

Purpose: Connects a socket to a remote address and port.

Parameters:

- `csock` (Type: `qsc_socket*`): A pointer to the socket.
- `address` (Type: `const char*`): The remote host's address.
- `port` (Type: `uint16_t`): The application port number.

Returns: `qsc_socket_exceptions` - The socket error.

9.4.19 Function: `mpdc_network_connect_to_device`

Purpose: Connects a socket to a remote address based on designation.

Parameters:

- `csock` (Type: `qsc_socket*`): A pointer to the socket.
- `address` (Type: `const char*`): The remote host's address.
- `designation` (Type: `mpdc_network_designations`): The remote host's designation.

Returns: `qsc_socket_exceptions` - The socket error.

9.4.20 Function: `mpdc_network_converge_request`

Purpose: Sends a convergence request from the DLA and broadcasts it to the network.

Parameters:

- `state` (Type: `const mpdc_network_converge_request_state*`): The converge request state structure.

Returns: `mpdc_protocol_errors` - The error code.

9.4.21 Function: `mpdc_network_converge_response`

Purpose: Responds to a DLA network converge request.

Parameters:

- `state` (Type: `const mpdc_network_converge_response_state*`): The converge response state structure.
- `packetin` (Type: `const mpdc_network_packet*`): The input packet containing the verify response.

Returns: `mpdc_protocol_errors` - The error code.

9.4.22 Function: `mpdc_network_converge_update_verify`

Purpose: Processes a converge response update message.

Parameters:

- state (Type: mpdc_network_converge_update_verify_state*): The converge update verify state structure.
- packetin (Type: const mpdc_network_packet*): The input packet containing the verify response.

Returns: mpdc_protocol_errors - The error code.

9.4.23 Function: mpdc_network_fkey_request

Purpose: Requests and executes a key exchange for a fragmentation key.

Parameters:

- state (Type: mpdc_network_fkey_request_state*): The fkey request state structure.

Returns: mpdc_protocol_errors - The error code.

9.4.24 Function: mpdc_network_fkey_response

Purpose: Responds to a key exchange request for a fragmentation key.

Parameters:

- state (Type: mpdc_network_fkey_response_state*): The fkey response state structure.
- packetin (Type: const mpdc_network_packet*): The input packet containing the request.

Returns: mpdc_protocol_errors - The error code.

9.4.25 Function: mpdc_network_fragment_collection_request

Purpose: Requests a fragment collection from a MAS.

Parameters:

- state (Type: mpdc_network_fragment_collection_request_state*): The fragment collection request state.

Returns: mpdc_protocol_errors - The error code.

9.4.26 Function: mpdc_network_fragment_collection_response

Purpose: Sends a collection response from the MAS to a client.

Parameters:

- state (Type: mpdc_network_fragment_collection_response_state*): The fkey response state structure.
- packetin (Type: const mpdc_network_packet*): The input packet containing the request.

Returns: mpdc_protocol_errors - The error code.

9.4.27 Function: mpdc_network_fragment_query_response

Purpose: Sends a fragment query response from an agent to a MAS.

Parameters:

- state (Type: mpdc_network_fragment_query_response_state*): The fragment query response state structure.
- packetin (Type: const mpdc_network_packet*): The input packet containing the request.

Returns: mpdc_protocol_errors - The error code.

9.4.28 Function: mpdc_network_get_local_address

Purpose: Retrieves the local IP address.

Parameters:

- address (Type: char[MPDC_CERTIFICATE_ADDRESS_SIZE]): Output array to store the local address.

Returns: bool - Returns true if the address is successfully retrieved.

9.4.29 Function: mpdc_network_incremental_update_request

Purpose: Sends an incremental update request.

Parameters:

- state (Type: const mpdc_network_incremental_update_request_state*): The incremental update request function state.

Returns: mpdc_protocol_errors - The error code.

9.4.30 Function: mpdc_network_incremental_update_response

Purpose: Sends a copy of a certificate to a remote host in response to an incremental update.

Parameters:

- state (Type: const mpdc_network_incremental_update_response_state*): The update response function state.
- packetin (Type: const mpdc_network_packet*): The input packet containing the request.

Returns: mpdc_protocol_errors - The error code.

9.4.31 Function: mpdc_network_mfk_exchange_request

Purpose: Requests and executes a key exchange request for a master fragmentation key.

Parameters:

- state (Type: mpdc_network_mfk_request_state*): The MFK request state structure.

Returns: mpdc_protocol_errors - The error code.

9.4.32 Function: mpdc_network_mfk_exchange_response

Purpose: Responds to a key exchange request for a master fragmentation key.

Parameters:

- state (Type: mpdc_network_mfk_response_state*): The MFK response state structure.
- packetin (Type: const mpdc_network_packet*): The input packet containing the request.

Returns: mpdc_protocol_errors - The error code.

9.4.33 Function: mpdc_network_port_to_application

Purpose: Gets the network designation based on a port number.

Parameters:

- port (Type: uint16_t): The network application port.

Returns: mpdc_network_designations - The network designation type.

9.4.34 Function: mpdc_network_register_request

Purpose: Sends an Agent join request to the DLA.

Parameters:

- state (Type: mpdc_network_register_request_state*): The join request function state.

Returns: mpdc_protocol_errors - The error code.

9.4.35 Function: mpdc_network_register_response

Purpose: Sends a join response to the agent.

Parameters:

- state (Type: mpdc_network_register_response_state*): The join response function state.
- packetin (Type: const mpdc_network_packet*): The input packet containing the request.

Returns: mpdc_protocol_errors - A protocol error flag.

9.4.36 Function: mpdc_network_register_update_request

Purpose: Sends a MAS or Client join update request to the DLA.

Parameters:

- state (Type: mpdc_network_register_update_request_state*): The join update request function state.

Returns: mpdc_protocol_errors - The error code.

9.4.37 Function: mpdc_network_register_update_response

Purpose: Sends a join update response to the server or client.

Parameters:

- state (Type: mpdc_network_register_update_response_state*): The join response function state.
- packetin (Type: const mpdc_network_packet*): The input packet containing the request.

Returns: mpdc_protocol_errors - A protocol error flag.

9.4.38 Function: mpdc_network_remote_signing_request

Purpose: Sends a certificate signing request from the DLA to the RDS.

Parameters:

- state (Type: mpdc_network_remote_signing_request_state*): The remote signing request state.

Returns: mpdc_protocol_errors - A protocol error flag.

9.4.39 Function: mpdc_network_remote_signing_response

Purpose: Sends a signed certificate response from the RDS to the DLA.

Parameters:

- state (Type: mpdc_network_remote_signing_response_state*): The remote signing response state.
- packetin (Type: const mpdc_network_packet*): The input packet containing the request.

Returns: mpdc_protocol_errors - A protocol error flag.

9.4.40 Function: mpdc_network_resign_request

Purpose: Sends a resign request to the DLA.

Parameters:

- state (Type: mpdc_network_resign_request_state*): The resign request state structure.

Returns: mpdc_protocol_errors - The error code.

9.4.41 Function: mpdc_network_resign_response

Purpose: Sends a resign response to the agent or server.

Parameters:

- state (Type: mpdc_network_resign_response_state*): The resign response state structure.
- packetin (Type: const mpdc_network_packet*): The input packet containing the request.

Returns: mpdc_protocol_errors - The error code.

9.4.42 Function: mpdc_network_revoke_broadcast

Purpose: Sends a revocation request from the DLA.

Parameters:

- state (Type: mpdc_network_revoke_request_state*): The revocation broadcast function state.

Returns: mpdc_protocol_errors - A protocol error flag.

9.4.43 Function: mpdc_network_revoke_response

Purpose: Verifies a revocation request sent from the DLA.

Parameters:

- state (Type: mpdc_network_revoke_response_state*): The revocation verify function state.
- packetin (Type: const mpdc_network_packet*): The input packet containing the request.

Returns: mpdc_protocol_errors - A protocol error flag.

9.4.44 Function: mpdc_network_send_error

Purpose: Sends an error message.

Parameters:

- csock (Type: const qsc_socket*): A pointer to the socket.
- error (Type: mpdc_protocol_errors): The error code.

Returns: mpdc_protocol_errors - The error code.

9.4.45 Function: mpdc_network_socket_dispose

Purpose: Shuts down and disposes of a socket instance.

Parameters:

- csock (Type: qsc_socket*): A pointer to the socket.

Returns: void

9.4.46 Function: mpdc_network_topological_query_request

Purpose: Queries a device for its topological information.

Parameters:

- state (Type: const mpdc_network_topological_query_request_state*): The topological query request state.

Returns: mpdc_protocol_errors - The error code.

9.4.47 Function: mpdc_network_topological_query_response

Purpose: Responds to a topological query request.

Parameters:

- state (Type: const mpdc_network_topological_query_response_state*): The topological query response state.
- packetin (Type: const mpdc_network_packet*): The packet containing the topological query request.

Returns: mpdc_protocol_errors - The error code.

9.4.48 Function: mpdc_network_topological_status_request

Purpose: Sends a status request from the DLA to a client device.

Parameters:

- state (Type: const mpdc_network_topological_status_request_state*): The topological status request state.
- query (Type: const char*): The device query string.

Returns: mpdc_protocol_errors - The error code.

9.4.49 Function: mpdc_network_topological_status_response

Purpose: Processes the status response from the client device and sends a response.

Parameters:

- state (Type: const mpdc_network_topological_status_response_state*): The topological status response state.
- packetin (Type: const mpdc_network_packet*): The packet containing the topological status request.

Returns: mpdc_protocol_errors - The error code.

9.4.50 Function: mpdc_network_topological_status_verify

Purpose: Verifies the status response from the DLA.

Parameters:

- state (Type: const mpdc_network_topological_status_request_state*): The topological status verify state.

- packetin (Type: const mpdc_network_packet*): The packet containing the topological status response.

Returns: mpdc_protocol_errors - The error code.

9.5 Topology.h

9.5.1 Function: mpdc_topology_address_from_issuer

Purpose: Retrieves an IP address based on an issuer string.

Parameters:

- address (Type: char*): The output array for the node's network address.
 - issuer (Type: const char*): The issuer string to look up.
 - list (Type: const mpdc_topology_list*): Pointer to the topology list.
-

9.5.2 Function: mpdc_topology_node_add_alias

Purpose: Adds an alias string to an issuer path.

Parameters:

- node (Type: mpdc_topology_node*): The network node to update.
 - alias (Type: const char*): The alias to add.
-

9.5.6 Function: mpdc_topology_nodes_are_equal

Purpose: Compares two topological nodes for equality.

Parameters:

- a (Type: const mpdc_topology_node*): First node for comparison.
- b (Type: const mpdc_topology_node*): Second node for comparison.

Returns: bool - Returns true if the nodes are identical.

9.5.7 Function: mpdc_topology_child_add_empty_node

Purpose: Retrieves an empty node pointer from the topology list (not thread-safe).

Parameters:

- list (Type: mpdc_topology_list*): Pointer to the topology list.

Returns: mpdc_topology_node* - Pointer to the node or NULL.

9.5.8 Function: mpdc_topology_child_add_item

Purpose: Adds a node to the topology list.

Parameters:

- list (Type: mpdc_topology_list*): Pointer to the topology list.
 - node (Type: const mpdc_topology_node*): Node to add.
-

9.5.9 Function: mpdc_topology_canonical_to_issuer_name

Purpose: Converts a canonical name to an issuer name.

Parameters:

- issuer (Type: char*): Output issuer name.
- isslen (Type: size_t): Length of the issuer name.
- domain (Type: const char*): The domain name.
- cname (Type: const char*): Input device canonical name.

Returns: bool - Returns false if the conversion failed.

9.5.10 Function: mpdc_topology_issuer_to_canonical_name

Purpose: Converts an issuer name to a canonical name.

Parameters:

- cname (Type: char*): Output canonical name.
- namelen (Type: size_t): Length of the canonical name string.

- issuer (Type: const char*): Input issuer name.

Returns: bool - Returns false if the conversion failed.

9.5.11 Function: mpdc_topology_child_register

Purpose: Registers a child node to a topology list.

Parameters:

- list (Type: mpdc_topology_list*): Pointer to the topology list.
 - ccert (Type: const mpdc_child_certificate*): Node's child certificate.
 - address (Type: const char*): Node's network address.
-

9.5.12 Function: mpdc_topology_list_clone

Purpose: Clones a topology list.

Parameters:

- tlist (Type: const mpdc_topology_list*): Pointer to the topology list to clone.
 - tcopy (Type: mpdc_topology_list*): Pointer to the new list.
-

9.5.13 Function: mpdc_topology_list_deserialize

Purpose: Deserializes a topology list.

Parameters:

- list (Type: mpdc_topology_list*): Pointer to the topology list.
 - input (Type: const uint8_t*): The serialized list.
 - inplen (Type: size_t): Size of the input array.
-

9.5.14 Function: mpdc_topology_list_dispose

Purpose: Disposes of the topology list and releases memory.

Parameters:

- list (Type: mpdc_topology_list*): Pointer to the topology list.
-

9.5.15 Function: mpdc_topology_list_initialize

Purpose: Initializes the topology list.

Parameters:

- list (Type: mpdc_topology_list*): Topology list state.
-

9.5.16 Function: mpdc_topology_list_item

Purpose: Retrieves a node from an index in the topology list.

Parameters:

- list (Type: mpdc_topology_list*): Topology list state.
- node (Type: mpdc_topology_node*): Pointer to the node structure.
- index (Type: size_t): Node index.

Returns: bool - Returns false if the item was not found.

9.5.17 Function: mpdc_topology_list_remove_duplicates

Purpose: Removes duplicate nodes from the topology list.

Parameters:

- list (Type: mpdc_topology_list*): Topology list state.

Returns: size_t - Number of items in the list.

9.5.18 Function: mpdc_topology_list_server_count

Purpose: Counts nodes of a specified type in the database.

Parameters:

- list (Type: const mpdc_topology_list*): Topology list state structure.
- ntype (Type: mpdc_network_designations): Type of node to count.

Returns: size_t - Number of nodes found.

9.5.19 Function: mpdc_topology_list_serialize

Purpose: Serializes a topology list.

Parameters:

- output (Type: uint8_t*): Output array for serialized topology.
- list (Type: const mpdc_topology_list*): Topology list state structure.

Returns: size_t - Size of the serialized topology.

9.5.20 Function: mpdc_topology_list_size

Purpose: Returns the byte size of a serialized topology list.

Parameters:

- list (Type: const mpdc_topology_list*): Topology list state structure.
-

9.5.21 Function: mpdc_topology_list_to_string

Purpose: Converts the topology list to a printable string.

Parameters:

- list (Type: const mpdc_topology_list*): Topology list state structure.
- output (Type: char*): Output array for the string.
- outlen (Type: size_t): Length of the output array.

Returns: size_t - Byte size of the serialized topology.

9.5.22 Function: mpdc_topology_list_update_pack

Purpose: Packs a node update set into an array.

Parameters:

- output (Type: uint8_t*): Output array for serialized topology.
- list (Type: const mpdc_topology_list*): Topology list state structure.
- ntype (Type: mpdc_network_designations): Type of node entry to pack.

Returns: size_t - Size of the serialized topology.

9.5.23 Function: mpdc_topology_list_update_unpack

Purpose: Unpacks a node update set into the topology list.

Parameters:

- list (Type: mpdc_topology_list*): Topology list state structure.
 - input (Type: const uint8_t*): Serialized topology array.
 - inplen (Type: size_t): Length of the input array.
-

9.5.24 Function: mpdc_topology_ordered_server_list

Purpose: Returns a sorted list of nodes by serial number.

Parameters:

- olist (Type: mpdc_topology_list*): Sorted output topology list.
- tlist (Type: const mpdc_topology_list*): Unsorted input topology list.
- ntype (Type: mpdc_network_designations): Type of node entry to sort.

Returns: size_t - Number of nodes in the list.

9.5.25 Function: mpdc_topology_node_clear

Purpose: Erases a node structure.

Parameters:

- node (Type: mpdc_topology_node*): Pointer to the topology node to erase.

9.5.26 Function: mpdc_topology_node_copy

Purpose: Copies a source node to a destination node structure.

Parameters:

- source (Type: const mpdc_topology_node*): Pointer to the source node.
 - destination (Type: mpdc_topology_node*): Pointer to the destination node.
-

9.5.27 Function: mpdc_topology_node_deserialize

Purpose: Deserializes a serialized topological node.

Parameters:

- node (Type: mpdc_topology_node*): Pointer to the topology node.
 - input (Type: const uint8_t*): Serialized topology node array.
-

9.5.28 Function: mpdc_topology_node_encode

Purpose: Encodes a topological node into a printable string.

Parameters:

- node (Type: mpdc_topology_node*): Pointer to the topology node.
- output (Type: char*): Serialized node string.

Returns: size_t - Size of the serialized node.

9.5.29 Function: mpdc_topology_node_exists

Purpose: Checks if a node exists in the topology list by serial number.

Parameters:

- list (Type: const mpdc_topology_list*): Topology list state.
- serial (Type: const uint8_t*): Node's serial number.

Returns: bool - Returns true if the node exists.

9.5.30 Function: mpdc_topology_node_find

Purpose: Finds a node in the list by serial number.

Parameters:

- list (Type: const mpdc_topology_list*): Topology list state.
- node (Type: mpdc_topology_node*): Pointer to the destination node.
- serial (Type: const uint8_t*): Certificate serial number.

Returns: bool - Returns false if the node was not found.

9.6 Agent

9.6.1 Function: mpdc_agent_pause_server

Purpose: Pause the Agent server

Returns: void

9.6.2 Function: mpdc_agent_start_server

Purpose: Start the Agent server

Returns: int - Returns zero on success

9.6.3 Function: mpdc_agent_stop_server

Purpose: Stop the Agent server

Returns: void

9.7 Client

9.7.1 Function: mpdc_client_pause_server

Purpose: Pause the Client server

Returns: void

9.7.2 Function: mpdc_client_start_server

Purpose: Start the Client server

Returns: int - Returns zero on success

9.7.3 Function: mpdc_client_stop_server

Purpose: Stop the Client server

Returns: void

9.8 DLA

9.8.1 Function: mpdc_dla_pause_server

Purpose: Pause the DLA server

Returns: void

9.8.2 Function: mpdc_dla_start_server

Purpose: Start the DLA server

Returns: int - Returns zero on success

9.8.3 Function: mpdc_dla_stop_server

Purpose: Stop the DLA server

Returns: void

9.9 MAS

9.9.1 Function: mpdc_mas_pause_server

Purpose: Pause the MAS server

Returns: void

9.9.2 Function: mpdc_mas_start_server

Purpose: Start the MAS server

Returns: int - Returns zero on success

9.9.3 Function: mpdc_mas_stop_server

Purpose: Stop the MAS server

Returns: void

9.10 RDS

9.10.1 Function: mpdc_rds_pause_server

Purpose: Pause the RDS server

Returns: void

9.10.2 Function: mpdc_rds_start_server

Purpose: Start the RDS server

Returns: int - Returns zero on success

9.10.3 Function: `mpdc_dla_stop_server`

Purpose: Stop the DLA server

Returns: void